

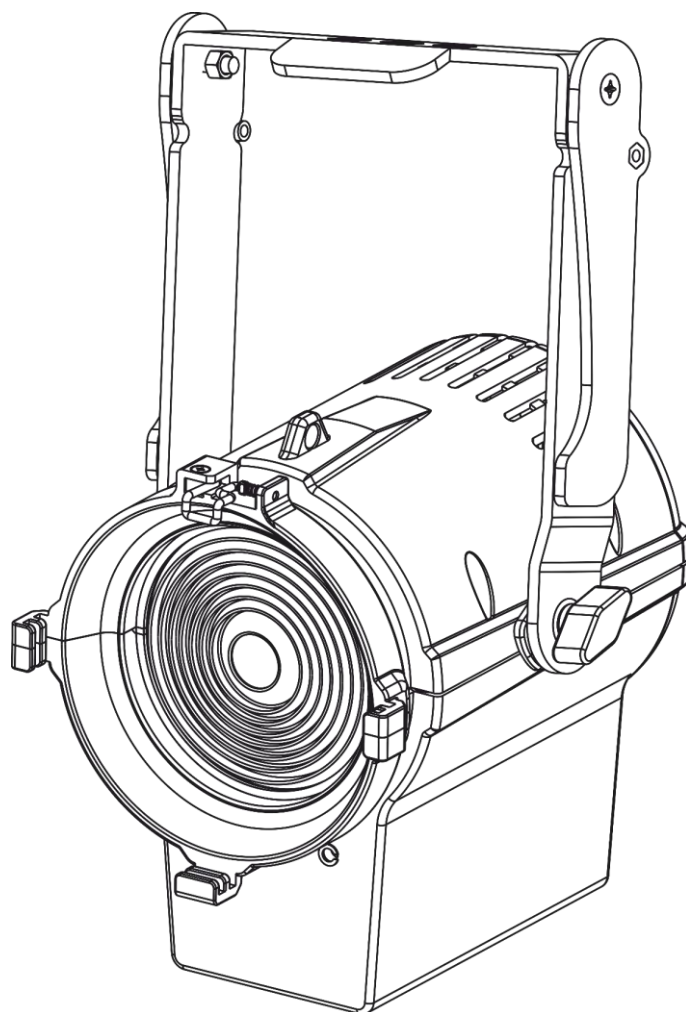

MANUAL



ENGLISH

Performer Fresnel Mini

V1

Ordercode: 33055

Table of contents

Warning	2
Safety Instructions	2
Operating Determinations	4
Rigging	4
Connection with the mains.....	6
Return Procedure.....	6
Claims.....	6
Description of the device	7
Features	7
Overview	8
Back.....	8
Installation	9
Installing Barndoor	9
Set Up and Operation	10
Control Mode	10
One Performer (Manual Mode)	10
Charging the built-in battery	10
Zoom operation	11
Battery endurance	12
Maintenance	13
Troubleshooting	13
No Light	13
No Response to DMX.....	13
Product Specifications	15
Dimensions	16
Notes	17

Warning



**For your own safety, please read this user manual carefully
before your initial start-up!**



Unpacking Instructions

Immediately upon receiving this product, carefully unpack the carton and check the contents to ensure that all parts are present, and have been received in good condition. Notify the dealer immediately and retain packing material for inspection if any parts appear damaged from shipping or the carton itself shows signs of mishandling. Save the carton and all packing materials. In the event that a fixture must be returned to the factory, it is important that the fixture be returned in the original factory box and packing.

Your shipment includes:

- Showtec Performer Fresnel Mini
- DC input voltage: 51VDC, 1A
- 1 x safety cable
- User manual

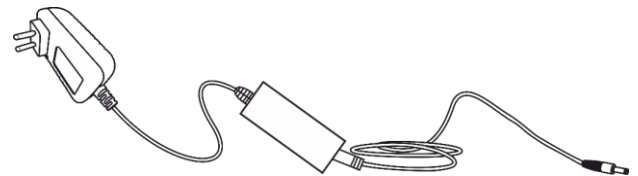
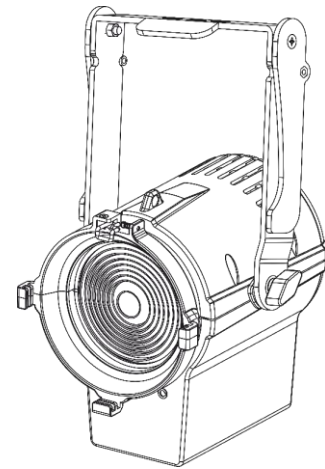

LED Expected Lifespan

LEDs gradually decline in brightness over time. HEAT is the dominant factor that leads to the acceleration of this decline. Packaged in clusters, LEDs exhibit higher operating temperatures than in ideal or singular optimum conditions. For this reason when all color LEDs are used at their fullest intensity, life of the LEDs is significantly reduced. If improving your lifespan expectancy is of a higher priority, place care in providing for lower operational temperatures. This may include climatic-environmental and the reduction of overall projection intensity.



CAUTION!

**Keep this device away from rain and moisture!
Unplug mains lead before opening the housing!**



Safety Instructions

Every person involved with the installation, operation and maintenance of this device has to:

- be qualified
- follow the instructions of this manual



**CAUTION! Be careful with your operations.
With a dangerous voltage you can suffer
a dangerous electric shock when touching the wires!**



Before your initial start-up, please make sure that there is no damage caused by transportation. Should there be any, consult your dealer and do not use the device.

To maintain perfect condition and to ensure a safe operation, it is absolutely necessary for the user to follow the safety instructions and warning notes written in this manual.

Please consider that damages caused by manual modifications to the device are not subject to warranty.

This device contains no user-serviceable parts. Refer servicing to qualified technicians only.

IMPORTANT:

The manufacturer will not accept liability for any resulting damages caused by the non-observance of this manual or any unauthorized modification to the device.

- Never let the power cord come into contact with other cables! Handle the power cord and all connections with the mains with particular caution!
- Never remove warning or informative labels from the unit.
- Never use anything to cover the ground contact.
- Never place any material over the lens.
- Never look directly into the light source.
- Never leave any cables lying around.
- Do not insert objects into air vents.
- Do not connect this device to a dimmer pack.
- Do not switch the device on and off in short intervals, as this would reduce the device's life.
- Do not touch the device's housing bare-handed during its operation. Allow the fixture to cool for at least 5 minutes before handling.
- Do not shake the device. Avoid brute force when installing or operating the device.
- Only operate the fixture after having checked if the housing is firmly closed and all screws are tightly fastened.
- Only operate the device after having familiarized with its functions.
- Avoid flames and do not put close to flammable liquids or gases.
- Always keep case closed while operating.
- Always allow free air space of at least 50 cm around the unit for ventilation.
- Always disconnect power from the mains, when device is not used or before cleaning! Only handle the power cord by the plug. Never pull out the plug by tugging the power cord.
- Make sure that the device is not exposed to extreme heat, moisture or dust.
- Make sure that the available voltage is not higher than stated on the rear panel.
- Make sure that the power cord is never crimped or damaged. Check the device and the power cord from time to time.
- If the lens is obviously damaged, it has to be replaced, so that its functions are not impaired due to cracks or deep scratches.
- If device is dropped or struck, disconnect mains power supply immediately. Have a qualified engineer inspect for safety before operating.
- If the device has been exposed to drastic temperature fluctuation (e.g. after transportation), do not switch it on immediately. The arising condensation water might damage your device. Leave the device switched off until it has reached room temperature.
- If your Showtec device fails to work properly, discontinue use immediately. Pack the unit securely (preferably in the original packing material), and return it to your Showtec dealer for service.
- For adult use only. Device must be installed out of the reach of children. Never leave the unit running unattended.
- Never attempt to bypass the thermostatic switch or fuses.
- The user is responsible for correct positioning and operating of the Performer Mini. The manufacturer will not accept liability for damages caused by the misuse or incorrect installation of this device.
- This device falls under protection class I. Therefore it is essential to connect the yellow/green conductor to earth.

- Repairs, servicing and electric connection must be carried out by a qualified technician.
- WARRANTY: Till one year after date of purchase.

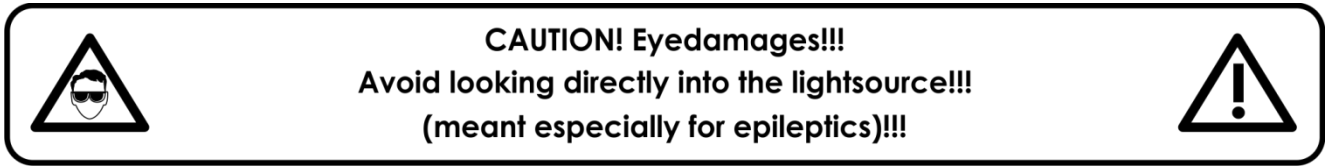

Operating Determinations

- This device is not designed for permanent operation. Consistent operation breaks will ensure that the device will serve you for a long time without defects.
- The minimum distance between light output and the illuminated surface must be bigger than 0,5 meter.
- The maximum ambient temperature $t_a = 40\text{ °C}$ must never be exceeded.
- In order to eliminate wear and improve the device's lifespan, during periods of non-use, completely disconnect from power source via breaker or by unplugging.
- The relative humidity must not exceed 50 % with an ambient temperature of 40 °C .
- If this device is operated in any other way, than the one described in this manual, the product may suffer damages and the warranty becomes void.
- Any other operation may lead to dangers like short-circuit, burns, electric shock, crash etc.

You endanger your own safety and the safety of others!

Rigging

Please follow the European and national guidelines concerning rigging, trussing and all other safety issues.

Do not attempt the installation yourself!

Always let the installation be carried out by an authorized dealer!

Procedure:

- If the Performer Mini is lowered from the ceiling or high joists, professional trussing systems have to be used.
- Use a clamp to mount the Performer Mini, with the mounting bracket, to the trussing system.
- The Performer Mini must never be fixed swinging freely in the room.
- The installation must always be secured with a safety attachment, e.g. an appropriate safety net or safety cable.
- When rigging, derigging or servicing the Performer Mini, always make sure, that the area below the installation place is blocked and staying in the area is forbidden.

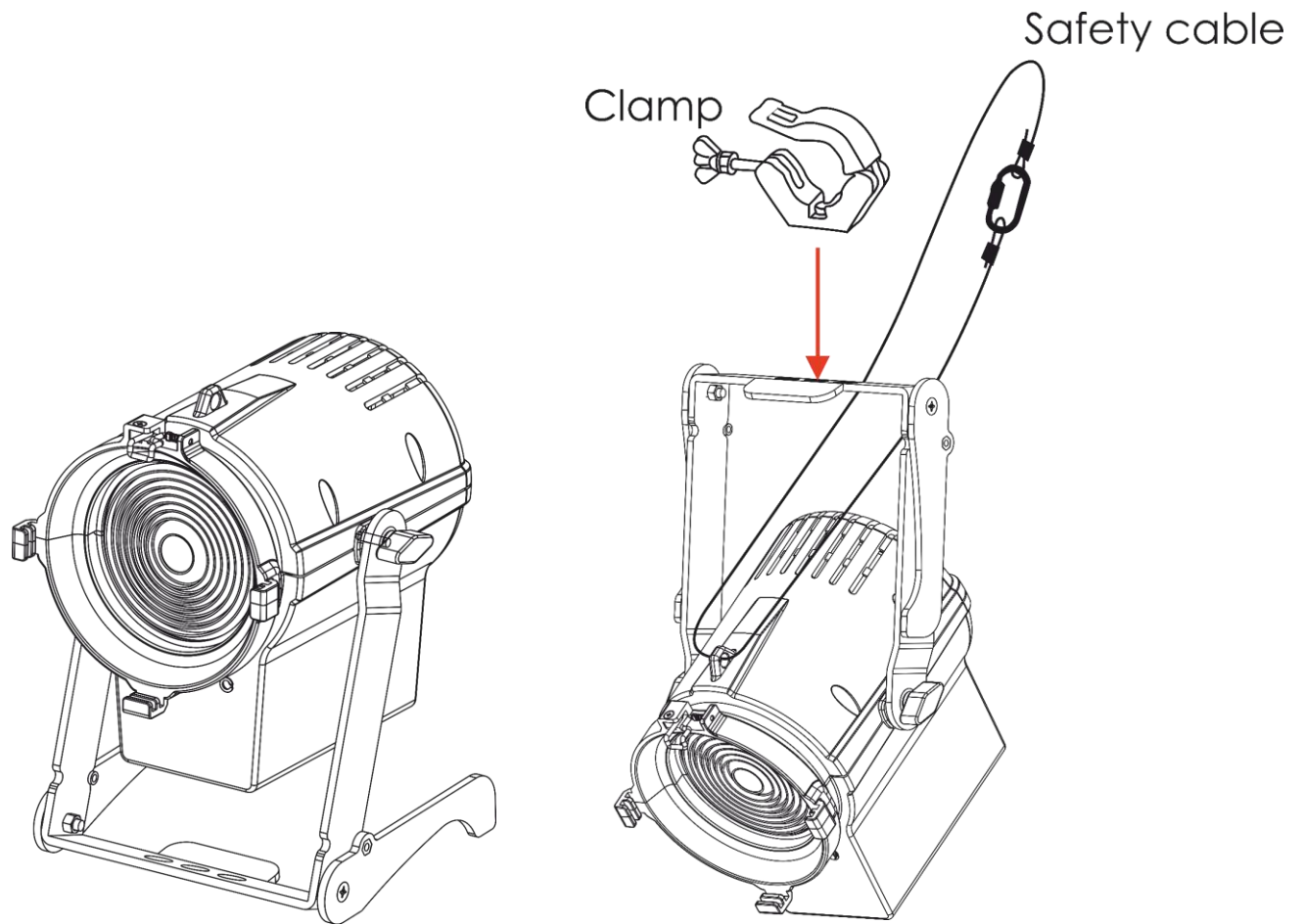

The Performer Fresnel Mini can be placed on a flat stage floor, by means of the included mounting bracket, or be mounted to any kind of truss with a clamp and a quick-lock bracket.

Improper installation can cause serious damage to people and property!

Connection with the mains

Connect the device to the mains with the power-plug.

Always pay attention, that the right color cable is connected to the right place.

International	EU Cable	UK Cable	US Cable	Pin
L	BROWN	RED	YELLOW/COPPER	PHASE
N	BLUE	BLACK	SILVER	NEUTRAL
	YELLOW/GREEN	GREEN	GREEN	PROTECTIVE GROUND

Make sure that the device is always connected properly to the earth!

Improper installation can cause serious damage to people and property!



Return Procedure



Returned merchandise must be sent prepaid and in the original packing, call tags will not be issued. Package must be clearly labeled with a Return Authorization Number (RMA number). Products returned without an RMA number will be refused. Highlite will not accept the returned goods or any responsibility. Call Highlite 0031-455667723 or mail aftersales@highlite.com and request an RMA prior to shipping the fixture. Be prepared to provide the model number, serial number and a brief description of the cause for the return. Be sure to properly pack fixture, any shipping damage resulting from inadequate packaging is the customer's responsibility. Highlite reserves the right to use its own discretion to repair or replace product(s). As a suggestion, proper UPS packing or double-boxing is always a safe method to use.

Note: If you are given an RMA number, please include the following information on a piece of paper inside the box:

- 01) Your name.
- 02) Your address.
- 03) Your phone number.
- 04) A brief description of the symptoms.

Claims

The client has the obligation to check the delivered goods immediately upon delivery for any shortcomings and/or visible defects, or perform this check after our announcement that the goods are at their disposal. Damage incurred in shipping is the responsibility of the shipper; therefore the damage must be reported to the carrier upon receipt of merchandise.

It is the customer's responsibility to notify and submit claims with the shipper in the event that a fixture is damaged due to shipping. Transportation damage has to be reported to us within one day after receipt of the delivery.

Any return shipment has to be made post-paid at all times. Return shipments must be accompanied with a letter defining the reason for return shipment. Non-prepaid return shipments will be refused, unless otherwise agreed in writing.

Complaints against us must be made known in writing or by fax within 10 working days after receipt of the invoice. After this period complaints will not be handled anymore.

Complaints will only then be considered if the client has so far complied with all parts of the agreement, regardless of the agreement of which the obligation is resulting.

Description of the device

Features

The Showtec Performer Fresnel Mini spotlights are extremely suitable for a wide range of applications. They can be used as accent lighting on decors, at company parties, in theatres and even for TV applications. Due to their compact design, they can be used anywhere. The manual zoom ensures that the bundle is adjustable in the right size and the supplied barn door ensures the correct design of the bundle.

There are 3 models:

- Battery version is the ideal solution for mobile solutions such as TV reports or interviews
- The DMX variant (33054) can be controlled with any DMX desk
- DDT model (33053) can be dimmed with a traditional dimmer pack and is therefore ideal for installations where you want to switch to LED light sources without adjusting the infrastructure

- Classic Compact Fresnel design
- High efficiency 30W LED source
- Fanless convection cooling
- Battery operated manual dimmer
- Input voltage: 100–240 V AC, 50/60 Hz
- DC input voltage: 51VDC, 1A
- Power consumption: 40 W
- Lightsource: Source: 1x 30W CREE LED
- Colour Temperature: 3100K
- Colour Rendering: >92Ra
- Lux@1m: 13500 (12°)
- Lux@1m: 3000 (40°)
- Battery: Lithium Ion
- Voltage: 44,2V
- Storage: 2,6Ah
- Battery life time: 6h@full
- Charging Cycle: 7h
- Control: Switch + Dimmer 5-100%
- Manual Zoom: 12°-40°
- Housing: Extruded Aluminium
- Colour: Black
- Fixture connection: DC charger input
- Barndoor: Optional (33056)
- Cooling: Air convection
- Operation Temperature: 0 °C ~ 40 °C
- IP Rating: IP20
- Dimensions: 275 x 175 x 188 mm (LxWxH)
- Weight: 2,3 Kg

Optional accessories

[33056](#) – Barndoor for Performer Fresnel Mini

Overview

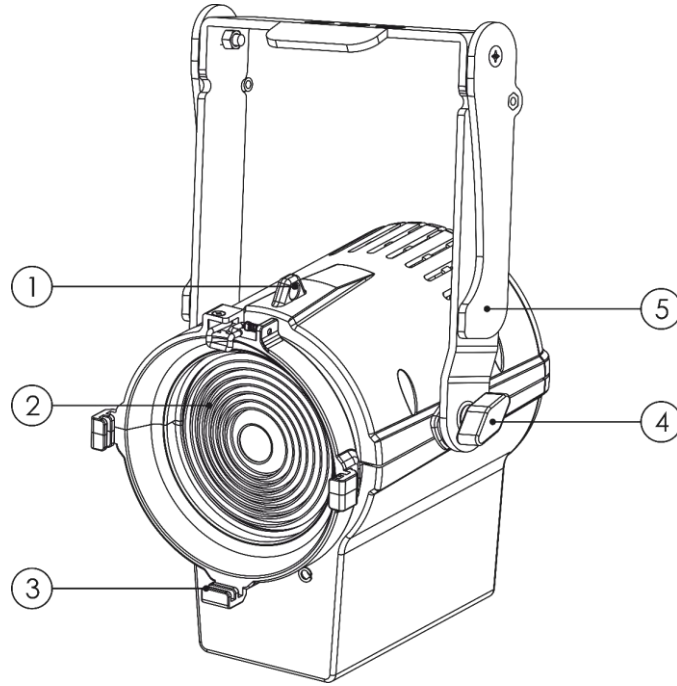

Fig. 01

- 01) Safety eye
- 02) 1x 30W LED
- 03) Filterframe
- 04) Mounting brackets with inclination screw
- 05) Adjustment screw

Back

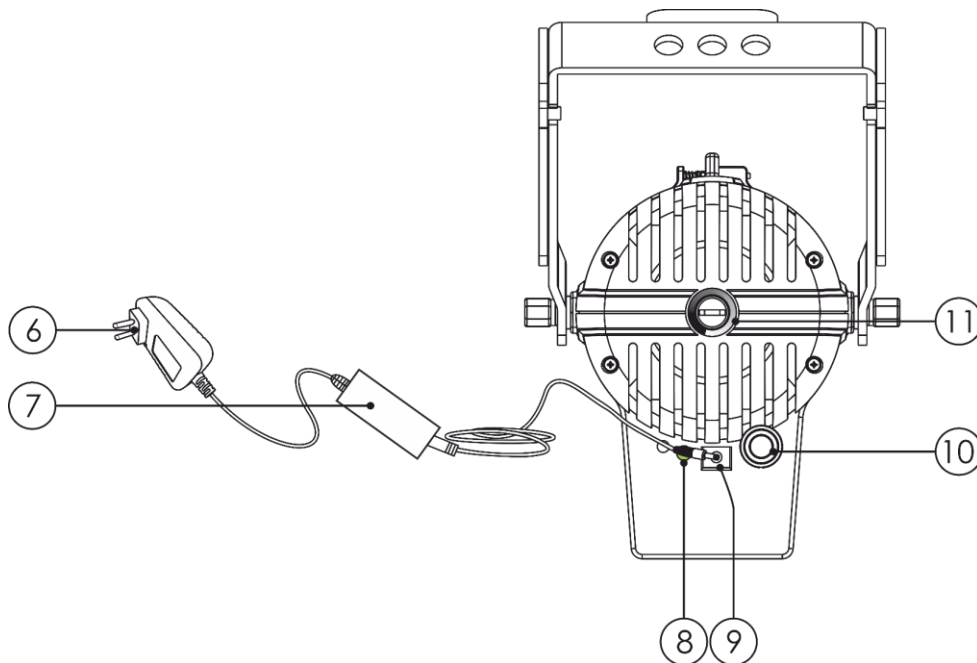

Fig. 02

- 06) Input voltage: 100–240 V AC, 50/60 Hz
- 07) Adapter
- 08) DC input voltage: 51VDC, 1A
- 09) Green Power LED
- 10) Manual Zoom: 12°-40°
- 11) Dimmer 5-100%

Installation

Remove all packing materials from the Performer Fresnel Mini. Check that all foam and plastic padding is removed. Connect all cables.

Do not supply power before the whole system is set up and connected properly.

Always disconnect from electric mains power supply before cleaning or servicing.

Damages caused by non-observance are not subject to warranty.

Installing Barndoor

- 01) Push the upper spring lever sideways.
- 02) Pull the upper spring lever in the direction of the arrow.
- 03) Make sure the upper lever is pulled backwards and insert the barndoor (ordercode: 33056) into the lower spring lever.
- 04) Release the upper spring lever.
- 05) Make sure the barndoor is firmly positioned between the upper spring lever and the lower spring lever.

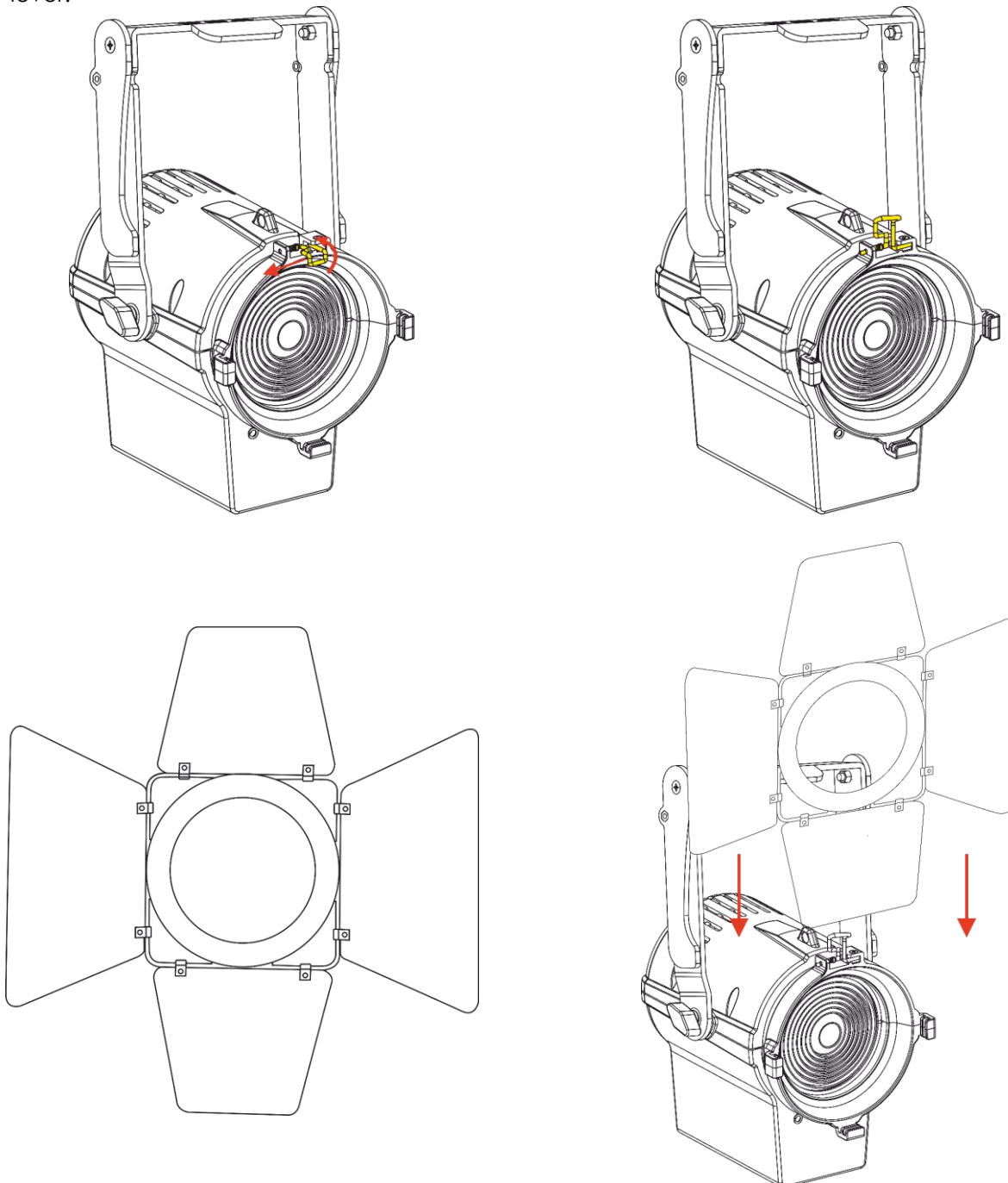

Fig. 03

Set Up and Operation

Follow the directions below, as they pertain to your preferred operation mode.

Before plugging the unit in, always make sure that the power supply matches the product specification voltage. Do not attempt to operate a 120V specification product on 230V power, or vice versa.

Control Mode

There is only 1 mode: • Manual

One Performer (Manual Mode)

- 01) Fasten the effect light onto firm trussing. Leave at least 0,5 meter on all sides for air circulation.
- 02) Always use a safety cable (ordercode 70140 / 70141).
- 03) Plug the adapter in the Performer Profile Mini.
- 04) Plug the end of the electric mains power cord into a proper electric power supply socket.
- 05) **For the light output to be visible, press the power switch ON/OFF (08). The current from the built-in battery is responsible for the light output. The True1 pro power cable should be used only when charging the battery.**
- 06) Please see page 26 for more information about Manual mode.

Charging the built-in battery

The device is equipped with an 18,5 V/13 AH lithium-ion battery.

- 01) Plug the adapter in the Performer Profile Mini.
- 02) Plug the end of the electric mains power cord into a proper electric power supply socket.
- 03) While the battery is charging, the red LED on the left-hand side of the display will light up.
- 04) When the battery is fully charged, the green LED on the left-hand side of the display will light up.



You cannot remove the lithium-ion battery and charge it separately.

The battery can only be charged when the DC adapter is connected to the Performer.



Important!

- Battery life time: 6h@full
- Charging Cycle: 7h
- Do not charge the lithium-ion battery for more than 24 hours.
- Please recharge the battery in time, for example when the battery is (almost) depleted. If you do not use the Performer for a long time, please recharge the battery at least once a month, in order to prevent the lithium-ion battery from becoming damaged.
- After a cycle use of 300 times, the battery capacity will be reduced (70% of the total 2,6 Ah capacity). Please reduce the charge and discharge times, to extend the battery lifetime. After 300 times of charging and discharging, you need to replace the battery.
- Store in the upright position.

Zoom operation

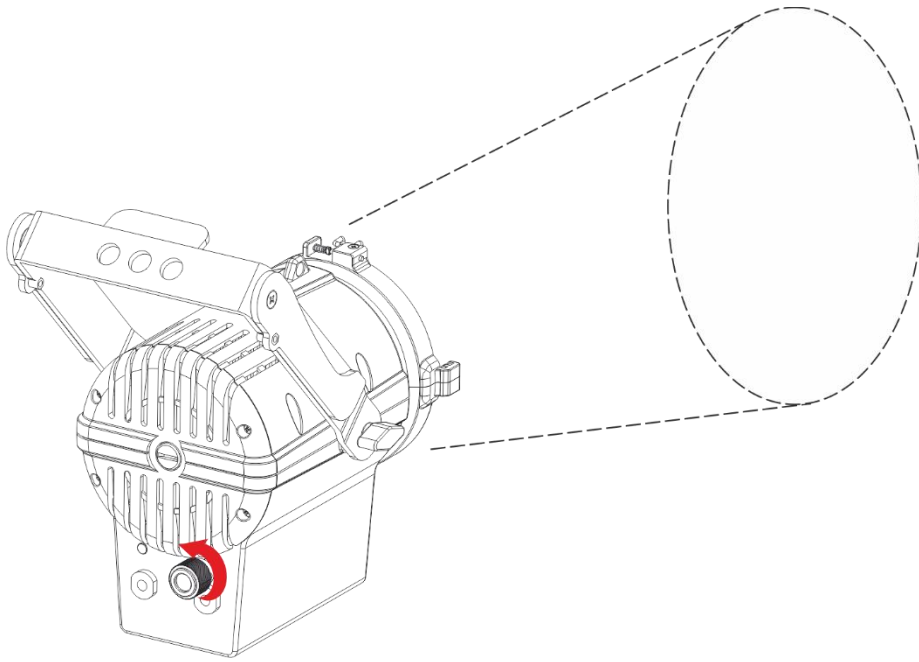

Turn the zoom button counter clockwise to increase the Angle.

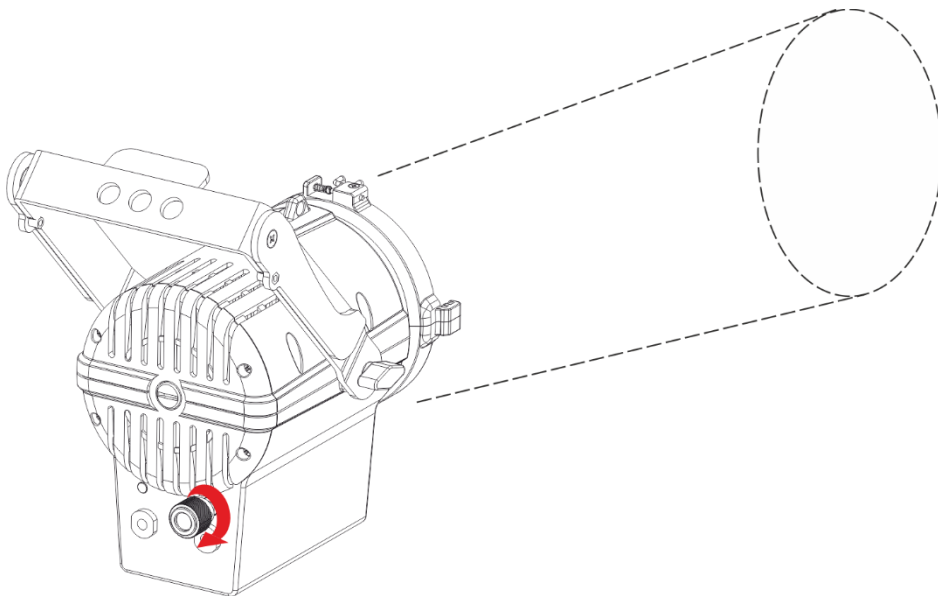

Turn the zoom button clockwise to reduce the Angle.

Battery endurance

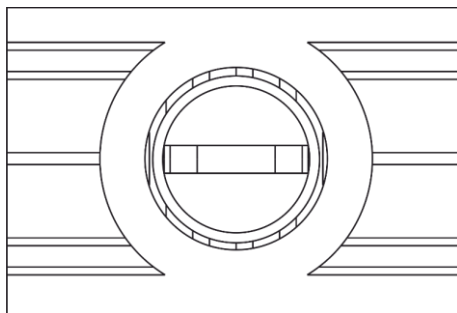
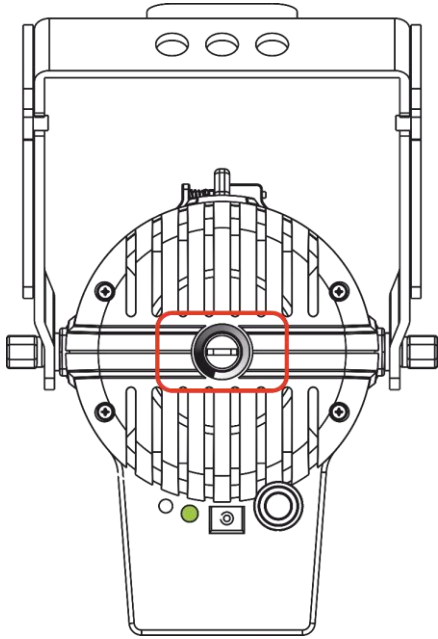

Battery lasts about 86.6h at 5.5% brightness (90 degree rotation)

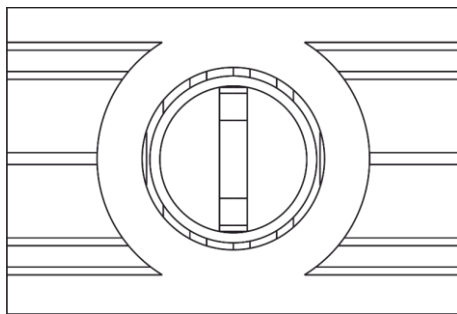

Battery lasts about 43.3h at 10% brightness (180 degree rotation)

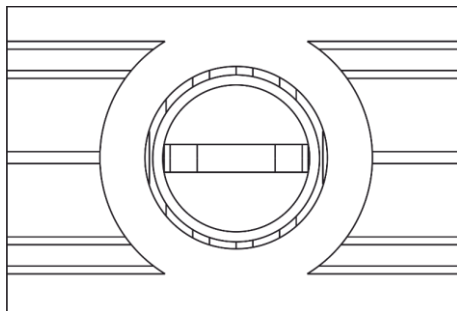

Battery lasts about 9.3h at 57% brightness (270 degree rotation)

Maintenance

The Showtec Performer Fresnel Mini requires almost no maintenance. However, you should keep the unit clean. Otherwise, the fixture's light output will be significantly reduced. Disconnect the mains power supply and then wipe the cover with a damp cloth. Wipe the front glass panel clean with glass cleaner and a soft cloth. Do not use alcohol or solvents. The front glass panel will require weekly cleaning, as smoke-fluid tends to build up residues, reducing the light output very quickly. Do not immerse in liquid. Keep connections clean. Disconnect electric power, and then wipe the DMX and audio connections with a damp cloth. Make sure connections are thoroughly dry before linking equipment or supplying electric power.

The operator has to make sure that safety-related and machine-technical installations are to be inspected by an expert after every year in the course of an acceptance test.

The operator has to make sure that safety-related and machine-technical installations are to be inspected by a skilled person once a year.

The following points have to be considered during the inspection:

- 01) All screws used for installing the device or parts of the device have to be tightly connected and must not be corroded.
- 02) There may not be any deformations on housings, fixations and installation spots.
- 03) Mechanically moving parts like axles, eyes and others may not show any traces of wearing.
- 04) The electric power supply cables must not show any damages or material fatigue.

Troubleshooting

No Light

If the light effect does not operate properly, refer servicing to a technician.

Suspect three potential problem areas as: the power supply, the LEDs, the internal fuse.

- 01) Power supply. Check if the unit is plugged into an appropriate power supply.
- 02) The LEDs. Return the Performer Fresnel Mini to your Showtec dealer.
- 03) The internal fuse. Return the Performer Fresnel Mini to your Showtec dealer.
- 04) If all appears to be O.K., plug the unit in again.
- 05) If you are unable to determine the cause of the problem, do not open the Performer Fresnel Mini, as this may damage the unit and the warranty will become void.
- 06) Return the device to your Showtec dealer.

No Response to DMX

- 01) Check the DMX setting. Make sure that DMX addresses are correct.
- 02) Check the DMX cable: Unplug the unit; change the DMX cable; then reconnect to electrical power. Try your DMX control again.
- 03) Determine whether the controller or light effect is at fault. Does the controller operate properly with other DMX products? If not, take the controller in for repair. If so, take the DMX cable and the light effect to a qualified technician.

Problem	Probable cause(s)	Remedy
One or more fixtures do not function at all	No power to the fixture	<ul style="list-style-type: none"> • Check if power is switched on and cables are plugged in
	Internal fuse blown	<ul style="list-style-type: none"> • Return the device to your Showtec dealer
Fixtures reset correctly, but all respond erratically or not at all to the controller	The controller is not connected	<ul style="list-style-type: none"> • Connect controller
	5-pin XLR Out of the controller does not match XLR In of the first fixture on the link (i.e. signal is reversed)	<ul style="list-style-type: none"> • Install a phase reversing cable between the controller and the first fixture on the link
Fixtures reset correctly, but some respond erratically or not at all to the controller	Poor data quality	<ul style="list-style-type: none"> • Check data quality. If much lower than 100 percent, the problem may be a bad data link connection, poor quality or broken cables, missing termination plug, or a defective fixture disturbing the link
	Bad data link connection	<ul style="list-style-type: none"> • Inspect connections and cables. Correct poor connections. Repair or replace damaged cables
	Data link not terminated with 120 Ohm termination plug	<ul style="list-style-type: none"> • Insert termination plug in output jack of the last fixture on the link
	Incorrect addressing of the fixtures	<ul style="list-style-type: none"> • Check address setting
	One of the fixtures is defective and disturbs data transmission on the link	<ul style="list-style-type: none"> • Bypass one fixture at a time until normal operation is regained: unplug both connectors and connect them directly together • Have the defective fixture serviced by a qualified technician
	5-pin XLR Out on the fixtures does not match (pins 2 and 3 reversed)	<ul style="list-style-type: none"> • Install a phase-reversing cable between the fixtures or swap pin 2 and 3 in the fixture, that behaves erratically
No light or LEDs cuts out intermittently	Fixture is too hot	<ul style="list-style-type: none"> • Allow the fixture to cool down • Make sure air vents are not blocked • Turn up the air conditioning
	LEDs damaged	<ul style="list-style-type: none"> • Disconnect fixture and return to your dealer
	The power supply settings do not match local AC voltage and frequency	<ul style="list-style-type: none"> • Disconnect fixture. Check settings and correct if necessary

Product Specifications

Model:	Showtec Performer Fresnel Mini
Input voltage:	100–240V AC, 50/60 Hz
DC input voltage:	51VDC, 1A
Power consumption:	20 W
Dimensions:	275 x 175 x 188 mm (LxWxH)
Weight:	2,54 kg (excl. adapter) 2,86 kg (incl. adapter)
Electro-mechanical effects:	
Light source:	1x High efficiency 30W CREE LED
Colour Temperature:	3100K
Colour Rendering:	>92Ra
Lux@1m:	13500 (12°)
Lux@1m:	3000 (40°)
Dimmer:	5-100%
Manual Zoom:	12°-40°
Battery:	Lithium-ion
Battery voltage:	44,2 V
Battery storage:	2,6 Ah
Battery life time:	6 h @ Full
Charging cycle:	7 h
IP rating:	IP20
Housing:	Extruded Aluminium
Fixture connection:	DC charger input
Cooling:	Air convection
Barndoor:	Optional (33056)
Working temperature:	0 °C ~ 40 °C
Max. ambient temperature t_a : 40 °C	Max. housing temperature t_B : 70 °C
Minimum distance:	
Minimum distance from flammable surfaces:	0,5 m
Minimum distance to lighted object:	1 m

Design and product specifications are subject to change without prior notice.



Website: www.Showtec.info
Email: service@highlite.com

Dimensions

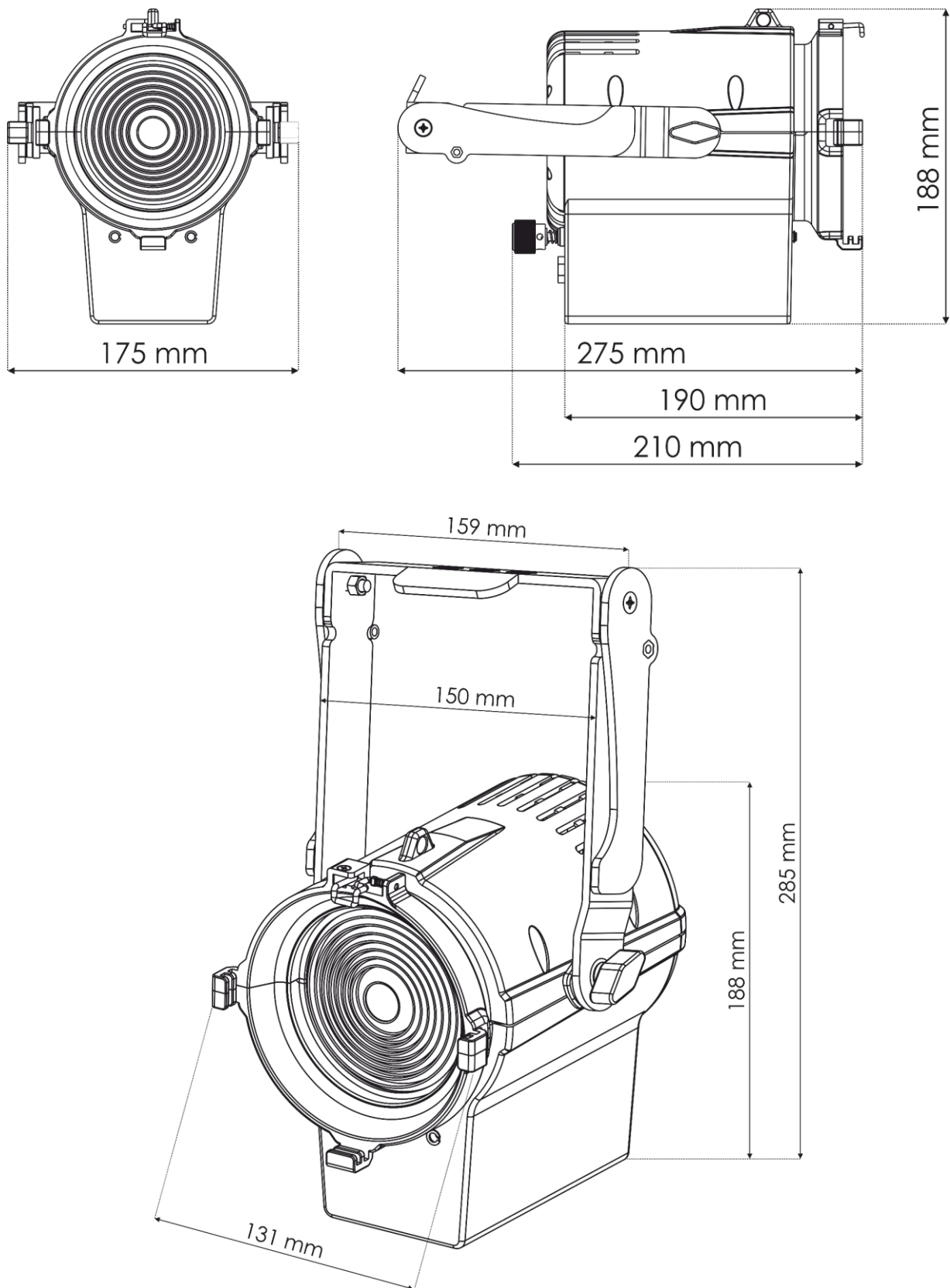



©2020 Showtec