

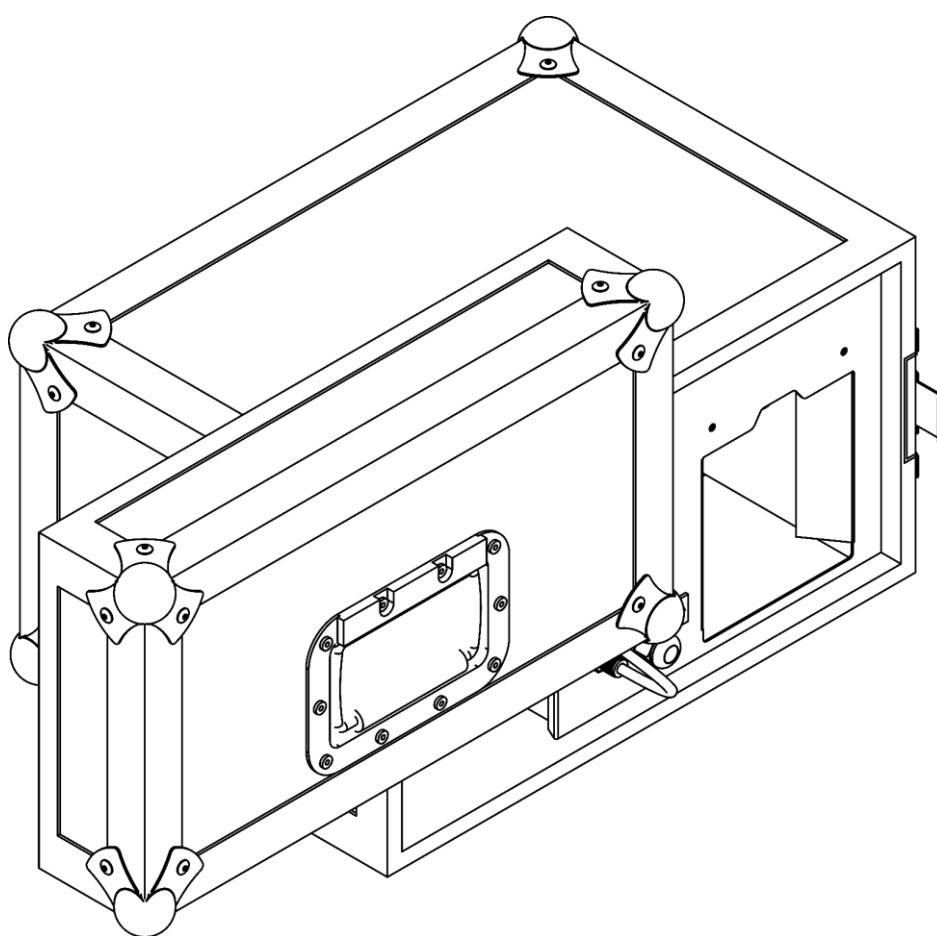

# MANUAL



**ENGLISH**

**WTF-FZ1500 1500W DMX Fazer V1**

**Ordercode: 61133**

**Table of contents**

<b>Warning</b> .....	2
Safety Instructions .....	2
Operating Determinations .....	4
Return Procedure .....	5
Claims.....	5
<b>Description of the device</b> .....	6
Overview .....	6
<b>Installation</b> .....	7
<b>Setup and Operation</b> .....	7
Tank Hose Installation .....	8
Control Modes.....	9
One WTF (Manual) .....	9
Multiple WTFs (DMX Control) .....	9
Fixture Linking.....	10
Data Cabling.....	10
Control Panel.....	11
Control Mode .....	11
DMX Addressing.....	11
Menu Overview.....	12
Main Menu Options .....	12
1. Interval Time.....	13
2. Duration Time.....	13
3. Timer Output.....	13
4. Volume Output .....	13
5. Fan Speed.....	13
6. DMX Address.....	13
7. DMX Mode .....	13
8. Quick Mode.....	14
9. Device Information.....	14
Manual Mode.....	14
1. Timer Mode .....	14
2. Volume Mode .....	14
DMX Channels .....	14
1 Channel.....	14
1 Channel (Sync) .....	15
2 Channels .....	15
<b>Maintenance</b> .....	15
Cleaning.....	15
Replacing the Fuse.....	15
<b>Troubleshooting</b> .....	16
No Response to DMX.....	17
<b>Product Specifications</b> .....	18

## Warning



**For your own safety, please read this user manual carefully  
before your initial start-up!**



### Unpacking Instructions

Immediately upon receiving this product, carefully unpack the carton and check the contents to ensure that all parts are present and have been received in good condition. Notify the dealer immediately and retain packing material for inspection if any parts appear damaged from shipping or the carton itself shows signs of mishandling. Save the carton and all packing materials. In the event that a fixture must be returned to the factory, it is important that the fixture be returned in the original factory box and packing.

### Your shipment includes:

- WTF-FZ1500 1500W DMX Fazer with a power cable (1,8 m)
- 1 x tank hose
- User manual

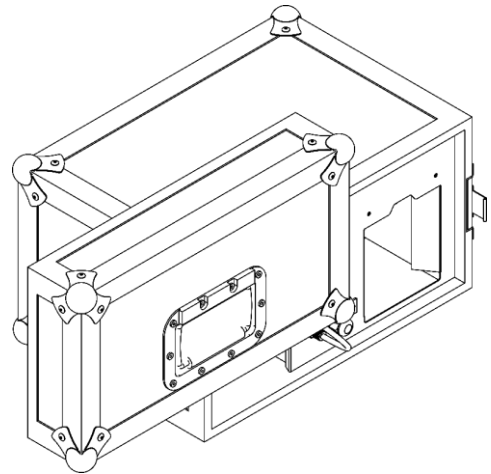

**CAUTION!**  
**Keep this device away from rain and moisture!**  
**Unplug mains lead before opening the housing!**



### Safety Instructions

Every person involved with the installation, operation and maintenance of this device has to:

- be qualified
- follow the instructions of this manual



**CAUTION! Be careful with your operations.**  
**With a dangerous voltage you can suffer  
a dangerous electric shock when touching the wires!**



Before your initial start-up, please make sure that there is no damage caused by transportation. Should there be any, consult your dealer and do not use the device.

To maintain perfect condition and to ensure a safe operation, it is absolutely necessary for the user to follow the safety instructions and warning notes written in this manual.

Please consider that damages caused by manual modifications to the device are not subject to warranty.

This device contains no user-serviceable parts. Refer servicing to qualified technicians only.

**IMPORTANT:**

The manufacturer will not accept liability for any resulting damages caused by the non-observance of this manual or any unauthorized modification to the device.

- Never let the power cord come into contact with other cables! Handle the power cord and all connections with the mains with particular caution!
- Always disconnect power from the mains, when device is not used or before cleaning ! Only handle the power cord by the plug. Never pull out the plug by tugging the power cord.
- Never remove warning or informative labels from the unit.
- Never use anything to cover the ground contact.
- Never aim the output nozzle directly at people.
- Never aim the output nozzle at open flames.
- Never add flammable liquids of any kind (oil, gas, perfume) to the fog liquid.
- Never drink fog liquid. If it is ingested, call a doctor immediately. If fog liquid comes in contact with skin or eyes, rinse thoroughly with water.
- Never lock fog-filled rooms. Risk: panic among the locked persons!
- Never use the device permanently! The output should be active only for short periods of time.
- Do not insert objects into air vents.
- Do not open the device and do not modify the device.
- Do not connect this device to a dimmer pack.
- Do not switch the device on and off in short intervals, as this would reduce the device's life.
- Do not touch the output nozzle bare-handed during its operation (output becomes very hot).
- Do not shake the device. Avoid brute force when installing or operating the device.
- Only use device indoors, avoid contact with water or other liquids.
- Only use device in well-ventilated rooms.
- Only use the high-quality fog liquid, recommended by your dealer (ordercodes: [60603](#), [60603B](#), [60629](#), [60637](#)). Other fog liquids may cause poor effect.
- Avoid flames and do not put close to flammable liquids or gases.
- Always make sure there is sufficient liquid in the fog liquid tank. Operating this unit without liquid can cause damage to the pump and the heater.
- Always allow free air space of at least 50 cm around the sides and top of the unit.
- Always allow free air space of at least 50 cm around the unit for ventilation.
- Make sure that the device is not exposed to extreme heat, moisture or dust.
- Make sure that all the required safety devices are in good condition and function properly.
- If text and/or icons are missing, damaged or illegible on the WTF, they should be replaced.
- Always drain tank before shipping or transporting this unit.
- Always keep tank cap closed while operating.
- Always keep the device upright.
- Always unplug the WTF before filling its tank.
- For adult use only. The fazer must be installed out of the reach of children. Never leave the unit running unattended.
- Always keep the nozzle at least 50 cm away from contact with anything, while in operation.
- Make sure that the available voltage is not higher than stated on the rear panel.
- Make sure that the power cord is never crimped or damaged. Check the device and the power-cord from time to time.
- If the external cable is damaged, it has to be replaced by a qualified technician.
- If device is dropped or struck, disconnect mains power supply immediately. Have a qualified engineer inspect for safety before operating.
- If the device has been exposed to drastic temperature fluctuation (e.g. after transportation), do not switch it on immediately. The arising condensation water might damage your device. Leave the device switched off until it has reached room temperature.
- If the WTF fails to work properly, discontinue use immediately. Remove all fog liquid from the tank. Pack the unit securely (preferably in the original packing material), and return it to your Showtec dealer for service.
- The fog vapour at the point of release is under pressure and is extremely hot.
- The output nozzle becomes very hot during operation (300 °C). Stay away and keep flammable materials at least 50 cm away from the nozzle.
- The use of fog liquid is only allowed for adults.
- In dense, fog-saturated surroundings, the oxygen portion is substantially reduced!

- The fog density must be portioned in a way that the visibility of at least 5 m is preserved. Risk: danger of anxiety state due to missing orientation!
- Every fog-filled room must be overseen by a skilled person.
- Allow time to cool down, before cleaning or servicing.
- Provide sufficient lighting of the surroundings when installing the device.
- The user is responsible for correct positioning and operating of the WTF. The manufacturer will not accept liability for unsafe situations, accidents, damages caused by:
  - The misuse or incorrect installation of this device.
  - Ignoring warnings or instructions as shown in this manual.
  - Using the WTF for purposes or in conditions other than specified in this manual.
  - Changes to the WTF. This includes the use of other than original spare parts.
  - Inadequate maintenance.
  - The unauthorized removal of safety symbols, safety covers and/or guards.
- Repairs, servicing and electric connection must be carried out by a qualified technician.
- WARRANTY: Till one year after date of purchase.

**CAUTION!**

**Do not perform any repairs on your own!  
If in doubt, always contact [service@highlite.com](mailto:service@highlite.com)!**

**CAUTION!**

**Follow all warnings and safety instructions during installation/operation!  
Non-observance could lead to severe injuries or even death !!!**

**Operating Determinations**

- This device is not designed for permanent operation. Consistent operation breaks will ensure that the device will serve you for a long time without defects.
- The maximum ambient temperature  $t_a = 40\text{ °C}$  must never be exceeded.
- In order to eliminate wear and improve the device's lifespan, during periods of non-use, completely disconnect from power source via breaker or by unplugging.
- The relative humidity must not exceed 50 % with an ambient temperature of  $40\text{ °C}$ .
- If this device is operated in any other way, than the one described in this manual, the product may suffer damages and the warranty becomes void.
- Any other operation may lead to dangers like short-circuit, burns, electric shock, crash etc.



We presume that you, your employees and others who come into contact with the WTF are familiar with how the machine must be dealt with. This includes the correct use, maintenance and repair of the WTF as described in this user manual. The employees should be familiar with the use of machines through training and/or experience.



*Improper installation can cause serious damage to people and property !*

*You endanger your own safety and the safety of others!*

Showtec excludes liability for unsafe situations, accidents and damage that are the result of:

- Disregard for the warnings or regulations as set out on the WTF or in this manual.
- Use for other purposes or under other circumstances than those set out in this documentation.
- Alterations to the WTF. This also includes the use of replacement parts other than the original ones.
- Insufficient maintenance.
- Unauthorised removal of safety caps and/or safeguards.
- Incompetent operation of the machine.

Showtec is not liable for any consequential loss in the event of a WTF breakdown.

**This user manual has been drawn up with the utmost care. Showtec cannot be held responsible for any mistakes made in this publication or for any consequences thereof.**

**Connection with the mains**

Connect the device to the mains with the power-plug.

Always pay attention, that the right color cable is connected to the right place.

International	EU Cable	UK Cable	US Cable	Pin
L	BROWN	RED	YELLOW/COPPER	PHASE
N	BLUE	BLACK	SILVER	NEUTRAL
	YELLOW/GREEN	GREEN	GREEN	PROTECTIVE GROUND

*Make sure that the device is always connected properly to the earth!*

*Improper installation can cause serious damage to people and property!*

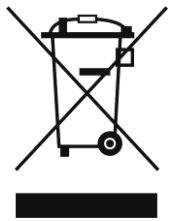

**⚠ Return Procedure ⚠**

Returned merchandise must be sent prepaid and in the original packing, call tags will not be issued. Package must be clearly labeled with a Return Authorization Number (RMA number). Products returned without an RMA number will be refused. Highlite will not accept the returned goods or any responsibility. Call Highlite 0031-455667723 or mail [aftersales@highlite.com](mailto:aftersales@highlite.com) and request an RMA prior to shipping the fixture. Be prepared to provide the model number, serial number and a brief description of the cause for the return. Be sure to properly pack fixture, any shipping damage resulting from inadequate packaging is the customer's responsibility. Highlite reserves the right to use its own discretion to repair or replace product(s). As a suggestion, proper UPS packing or double-boxing is always a safe method to use.

**Note: If you are given an RMA number, please include the following information on a piece of paper inside the box:**

- 01) Your name
- 02) Your address
- 03) Your phone number
- 04) A brief description of the symptoms

**Claims**

The client has the obligation to check the delivered goods immediately upon delivery for any short-comings and/or visible defects, or perform this check after our announcement that the goods are at their disposal. Damage incurred in shipping is the responsibility of the shipper; therefore the damage must be reported to the carrier upon receipt of merchandise.

It is the customer's responsibility to notify and submit claims with the shipper in the event that a fixture is damaged due to shipping. Transportation damage has to be reported to us within one day after receipt of the delivery.

Any return shipment has to be made post-paid at all times. Return shipments must be accompanied with a letter defining the reason for return shipment. Non-prepaid return shipments will be refused, unless otherwise agreed in writing.

Complaints against us must be made known in writing or by fax within 10 working days after receipt of the invoice. After this period complaints will not be handled anymore.

Complaints will only then be considered if the client has so far complied with all parts of the agreement, regardless of the agreement of which the obligation is resulting.

## Description of the device

### Features

The Showtec WTF series offers a range of fog and haze effect machines. The current range contains 2 foggers: the WTF-F800 and the WTF-F1000, that can fill your venue with fog in no time. The WTF-FZ1500 produces a more subtle, almost haze-like, smoke. The density of the smoke can be controlled through the built-in fan. The powerful WTF-J800 JET machine completes the WTF series. This machine can be used as a special FX on stage and the illumination of the LEDs give the vertical fog jet an extra dimension.

- Input voltage: 220–240 V AC, 50/60 Hz
- Power consumption: 1450 W
- Heater: 1450 W
- Output: 6000 cu.ft/min
- Heating time: 1,5 minutes
- Tank capacity: 5 L
- Liquid consumption: 5,1 ml/min (full output)
- Control modes: Manual, DMX-512
- DMX mode: 1, 1, 2 channels
- Color: Black
- Housing: Metal & flame-retardant plastic
- Data connection: 3-pin/5-pin XLR IN/OUT
- Power connection: Fixed Schuko power cable (1,8 m)
- IP rating: IP20
- Dimensions: 438 x 395 x 260 mm (LxWxH)
- Weight: 13,3 kg

### Optional accessories:

- [60603](#) – Showtec Fog Fluid Regular (5 L)
- [60603B](#) – Showtec Fog Fluid Regular (no label, 5 L)
- [60629](#) – Showtec Fog Fluid Light (5 L)
- [60637](#) – Showtec Fog Fluid High Density (5 L)

### Overview

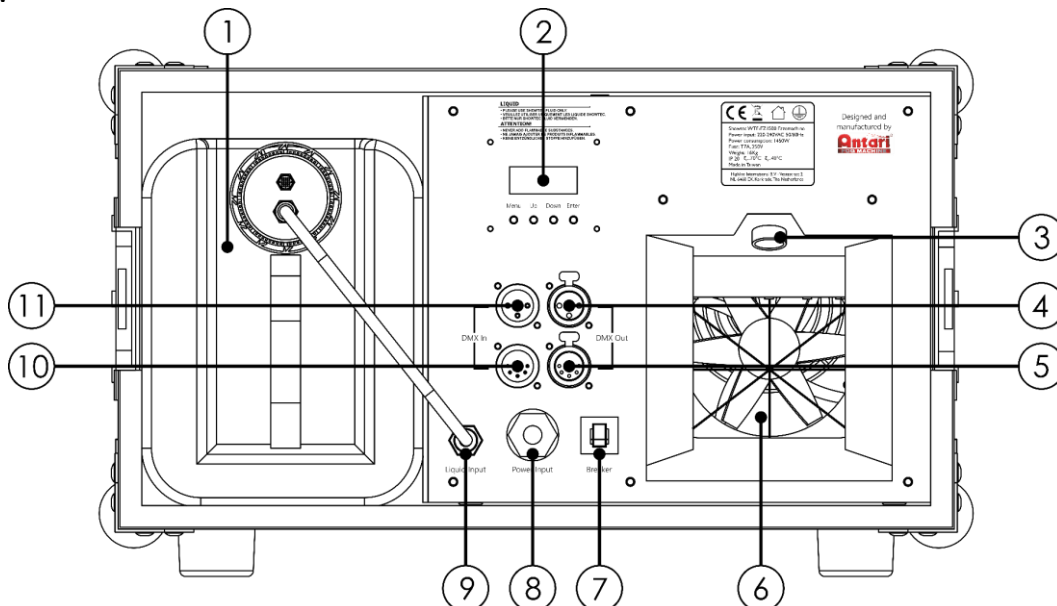

**Fig. 01**

- |                                    |                                   |
|------------------------------------|-----------------------------------|
| 01) Fog liquid tank (5 L)          | 07) Breaker                       |
| 02) LCD display + control buttons  | 08) Schuko power cable (1,8 m)    |
| 03) Output nozzle                  | 09) Liquid input                  |
| 04) 3-pin DMX signal connector OUT | 10) 5-pin DMX signal connector IN |
| 05) 5-pin DMX signal connector OUT | 11) 3-pin DMX signal connector IN |
| 06) Fan                            |                                   |

## Installation

Remove all packing materials from the WTF-FZ1500. Check if all foam and plastic padding is removed, especially in the fog output area.

Carefully add a fog liquid to the fog liquid tank. Do not overfill the tank! Use the WTF only with the Showtec fog liquids (ordercodes: [60603](#), [60603B](#), [60629](#), [60637](#)). Any other types of liquid can damage the unit.

The unit can be operated at floor level or be placed on any regular surface.

Regardless of the installation method, the device must always be placed in horizontal position.

The maximum inclination angle of the device should not exceed 15°.

**Always disconnect from electric mains power supply before cleaning or servicing.**

**Damages caused by non-observance are not subject to warranty.**



### CAUTION!

**Read all the warnings and safety instructions before installation!  
Knowledge of safety instructions is CRUCIAL for a safe use!**



### CAUTION!

**Follow all warnings and safety instructions during installation/operation!  
Non-observance could lead to severe injuries or even death !!!**



Always follow the instructions from this manual and from local authorities.

### Precautions for operation



Using a damaged or an improperly installed machine can lead to death, serious injury or property damage. Always inspect the machine thoroughly before operation.



Missing or obscured safety symbols on the machine can cause unawareness, which in turn can lead to death, serious injury or property damage. Make sure all safety symbols are correctly in place and visible. See front side of the device.

## Setup and Operation

Before plugging the unit in, always make sure that the power supply matches the product specification voltage. Do not attempt to operate a 110 V specification product on 240 V power, or vice versa.

### Note:

- **Always monitor the fog tank liquid level!**
- **Do not exceed the maximum fog liquid level. DO NOT OVERFILL!**
- **You can only fill 80 % of the tank (not more than 4 L in the tank, due to compression).**
- **Do not operate the fazer without fog liquid. It can permanently damage the device!**
- **Never aim the output nozzle directly at people.**
- **Never shut down the WTF while the device is operating.**
- **Installation and operation of the WTF requires professional and trained personnel.**



### Tank Hose Installation

- 01) Loosen the cap on the liquid input (09) and remove it. See Fig. 02.
- 02) Put the tank hose through the cap and attach it firmly to the liquid input (09). See Fig. 03.
- 03) Replace the cap and tighten it around the liquid input (09). See Fig. 04.



Fig. 02

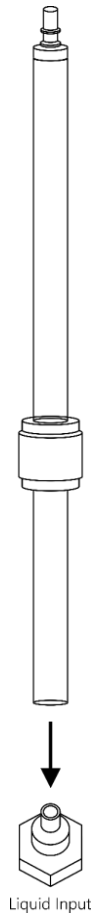

Fig. 03

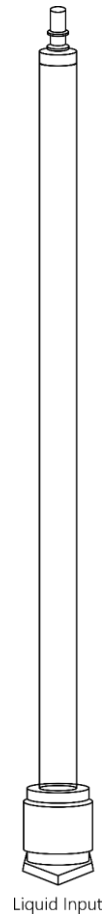

Fig. 04

- 04) Attach the other end of the tank hose to the fog liquid tank cap. See Fig. 05.

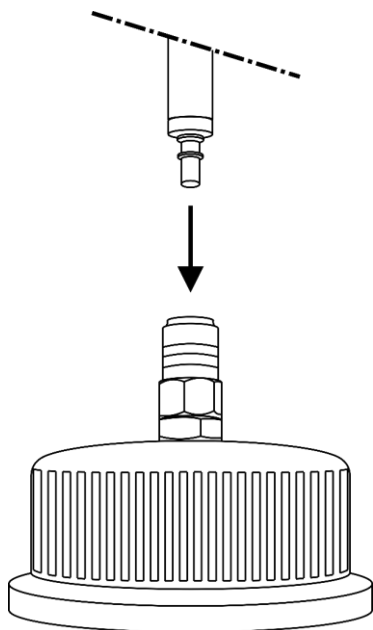

Fig. 05

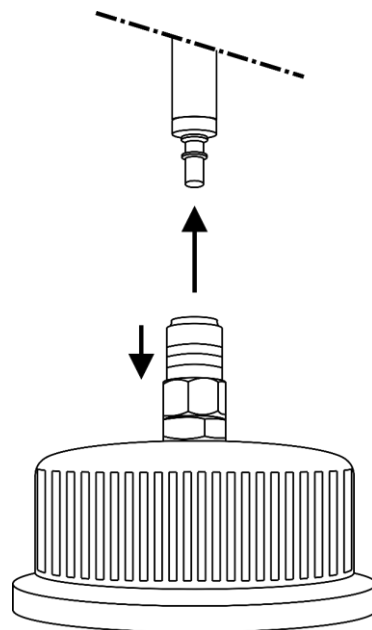

Fig. 06

- 05) To uninstall the tank hose, pull on the quick lock located on the fog liquid tank cap and remove the tank hose. See Fig. 06.

**Start-up**

Plug the power cord into a grounded electrical outlet. The machine will now re-heat to the proper operating temperature. Once the proper temperature has been reached, the main menu will appear.

**Control Modes**

- There are 2 modes:
- Manual
  - DMX-512 (1CH, 1CH, 2CH)

**One WTF (Manual)**

- 01) Leave at least 0,5 meter on all sides for air circulation.
- 02) Plug the end of the electric mains power cord into a proper electric power supply socket.
- 03) When the WTF is not connected with a DMX cable, it functions as a stand-alone device.
- 04) Please see page 14 for more information about Manual mode.

**Multiple WTFs (DMX Control)**

- 01) Fasten the effect light onto firm trussing. Leave at least 0,5 meter on all sides for air circulation.
- 02) Plug the end of the electric mains power cord into a proper electric power supply socket.
- 03) Use a 3-pin/5-pin XLR cable to connect the WTFs and other devices.

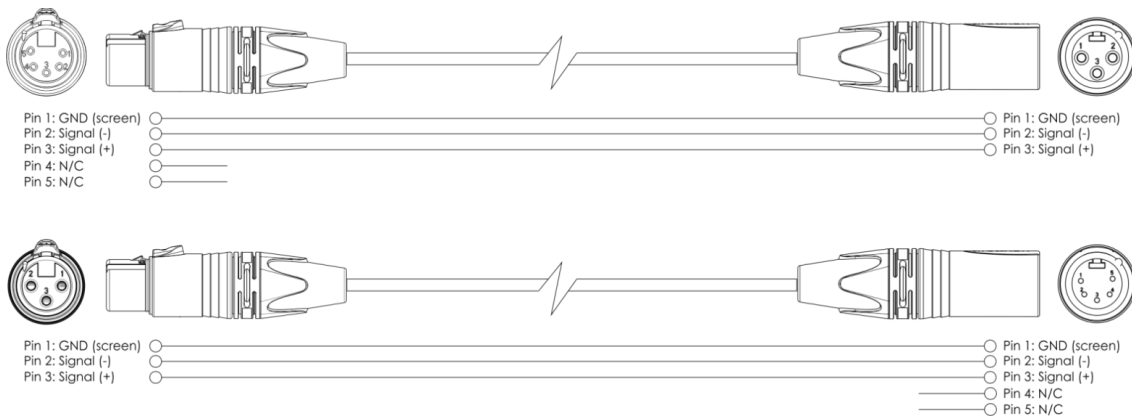

- 04) Link the units as shown in Fig. 07. Connect a DMX signal cable from the first unit's DMX "out" socket to the second unit's "in" socket. Repeat this process to link the second, third, and fourth units.
- 05) Supply electric power: Plug electric mains power cords into proper electric power supply sockets, starting with the first unit. Do not supply power before the whole system is set up and connected properly.

**Multiple WTFs DMX Setup**

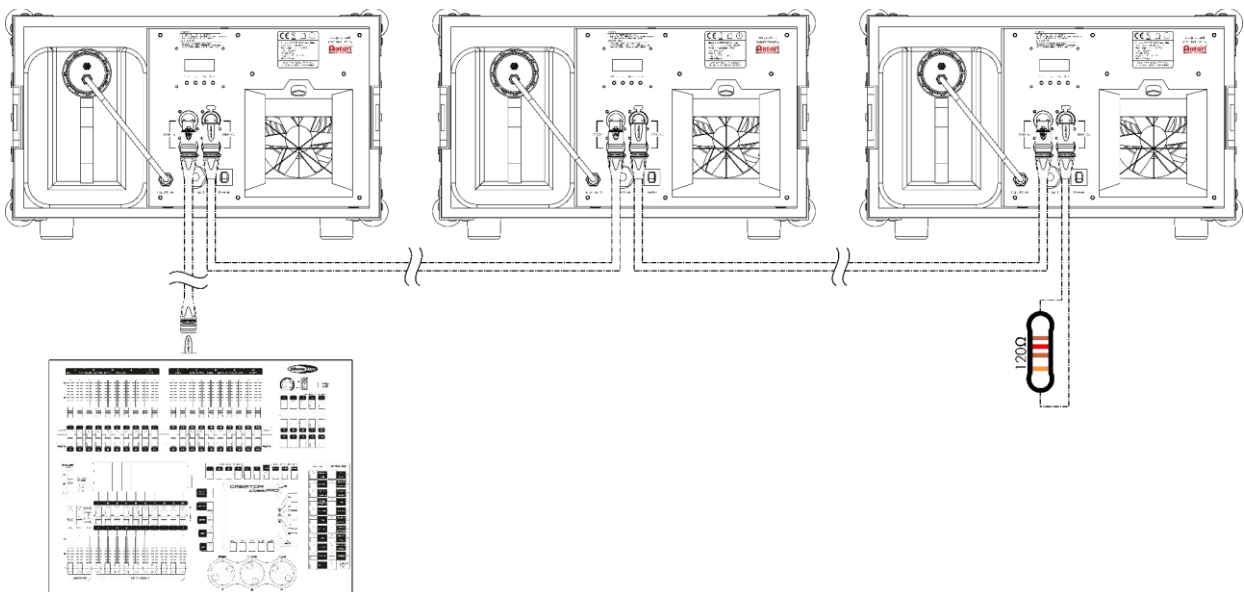

**Fig. 07**

**Note: Link all cables before connecting electric power**

## Fixture Linking

You will need a serial data link to run light shows of one or more fixtures using a DMX-512 controller or to run synchronized shows of two or more fixtures set to a master/slave operating mode. The combined number of channels required by all the fixtures on a serial data link determines the number of fixtures the data link can support.

**Important:** Fixtures on a serial data link must be daisy-chained in a single line. To comply with the EIA-485 standard, no more than 30 devices should be connected on one data link. Connecting more than 30 fixtures on one serial data link without the use of a DMX optically isolated splitter may result in deterioration of the digital DMX signal.

Maximum recommended DMX data link distance: 100 meters  
 Maximum recommended number of fixtures on a DMX data link: 30 fixtures  
 Maximum recommended number of fixtures on a power link @ 240 V: 1 fixture



## Data Cabling

To link fixtures together, you must obtain data cables. You can purchase DAP Audio certified DMX cables directly from a dealer/distributor or construct your own cable. If you choose to create your own cable, please use data-grade cables that can carry a high quality signal and are less prone to electromagnetic interference.

### DAP Audio DMX Data Cables

- DAP Audio Basic microphone cable for allround use. bal. XLR/M 3-pin > XLR/F 3-pin. **Ordercode** FL01150 (1,5 m), FL013 (3 m), FL016 (6 m), FL0110 (10 m), FL0115 (15 m), FL0120 (20 m).
- DAP Audio X-type data cable XLR/M 3-pin > XLR/F 3-pin. **Ordercode** FLX0175 (0,75 m), FLX01150 (1,5 m), FLX013 (3 m), FLX016 (6 m), FLX0110 (10 m).
- DAP Audio cable for the demanding user with exceptional audio-qualities and connector made by Neutrik®. **Ordercode** FL71150 (1,5 m), FL713 (3 m), FL716 (6 m), FL7110 (10 m).
- DAP Audio cable for the demanding user with exceptional audio-qualities and connector made by Neutrik®. **Ordercode** FL7275 (0,75 m), FL72150 (1,5 m), FL723 (3 m), FL726 (6 m), FL7210 (10 m).
- DAP Audio 110 Ohm cable with digital signal transmission. **Ordercode** FL0975 (0,75 m), FL09150 (1,5 m), FL093 (3 m), FL096 (6 m), FL0910 (10 m), FL0915 (15 m), FL0920 (20 m).
- DAP Audio data cable FL08 DMX/AES-EBU, XLR/M 5-pin > XLR/F 5-pin. **Ordercode** FL08150 (1,5 m), FL083 (3 m), FL086 (6 m), FL0810 (10 m), FL0820 (20 m).
- DAP Audio DMX adapter: 5-pin/3-pin. **Ordercode** FLA29.
- DAP Audio DMX adapter: 3-pin/5-pin. **Ordercode** FLA30.
- DAP Audio DMX Terminator 3-pin. **Ordercode** FLA42.
- DAP Audio DMX Terminator 5-pin. **Ordercode** FLA43.

The WTF-FZ1500 can be operated with a controller in **control mode** or without the controller in **stand-alone mode**.

### Control Panel

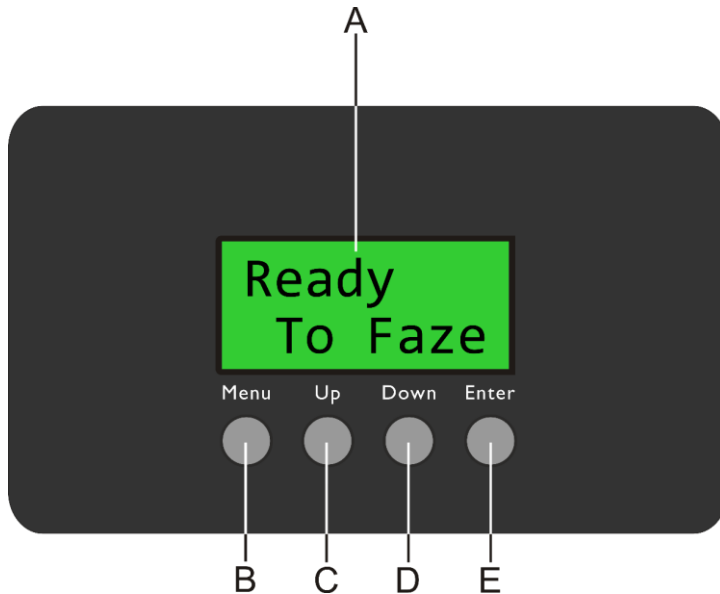

- A) LCD display
- B) MENU button
- C) UP button
- D) DOWN button
- E) ENTER button

Fig. 08

### Control Mode

The fixtures are individually addressed on a data-link and connected to the controller. The fixtures respond to the DMX signal from the controller. (When you select the DMX address and save it, the controller will display the saved DMX address, next time.)

### DMX Addressing

The control panel on the front side of the base allows you to assign DMX fixture addresses, which is the first channel with which the WTF will respond to the controller.

Please note when you use the controller, the unit has **2** channels.

When using multiple WTFs, make sure that you set the DMX addresses right.

Therefore, the DMX address of the first WTF should be **1(001)**; the DMX address of the second WTF should be **1+2=3 (003)**; the DMX address of the third WTF should be **3+2=5 (005)**, etc.

Please, make sure that you do not have any overlapping channels in order to control each WTF correctly. If two or more WTFs are addressed similarly, they will work similarly.

### Controlling:

After having addressed all WTF fixtures, you may now start operating these via your lighting controller.

**Note:** After switching on, the WTF will automatically detect whether DMX 512 data is received or not. If there is no data received at the DMX input, the "LED" on the control panel will not flash.

If not, the problem may be:

- The XLR cable from the controller is not connected with the input of the WTF.
- The controller is switched off or defective, the cable or connector is defective, or the signal wires are swapped in the input connector.

**Note:** It is necessary to insert an XLR termination plug (with 120 Ohm) in the last fixture in order to ensure proper transmission on the DMX data link.

Menu Overview

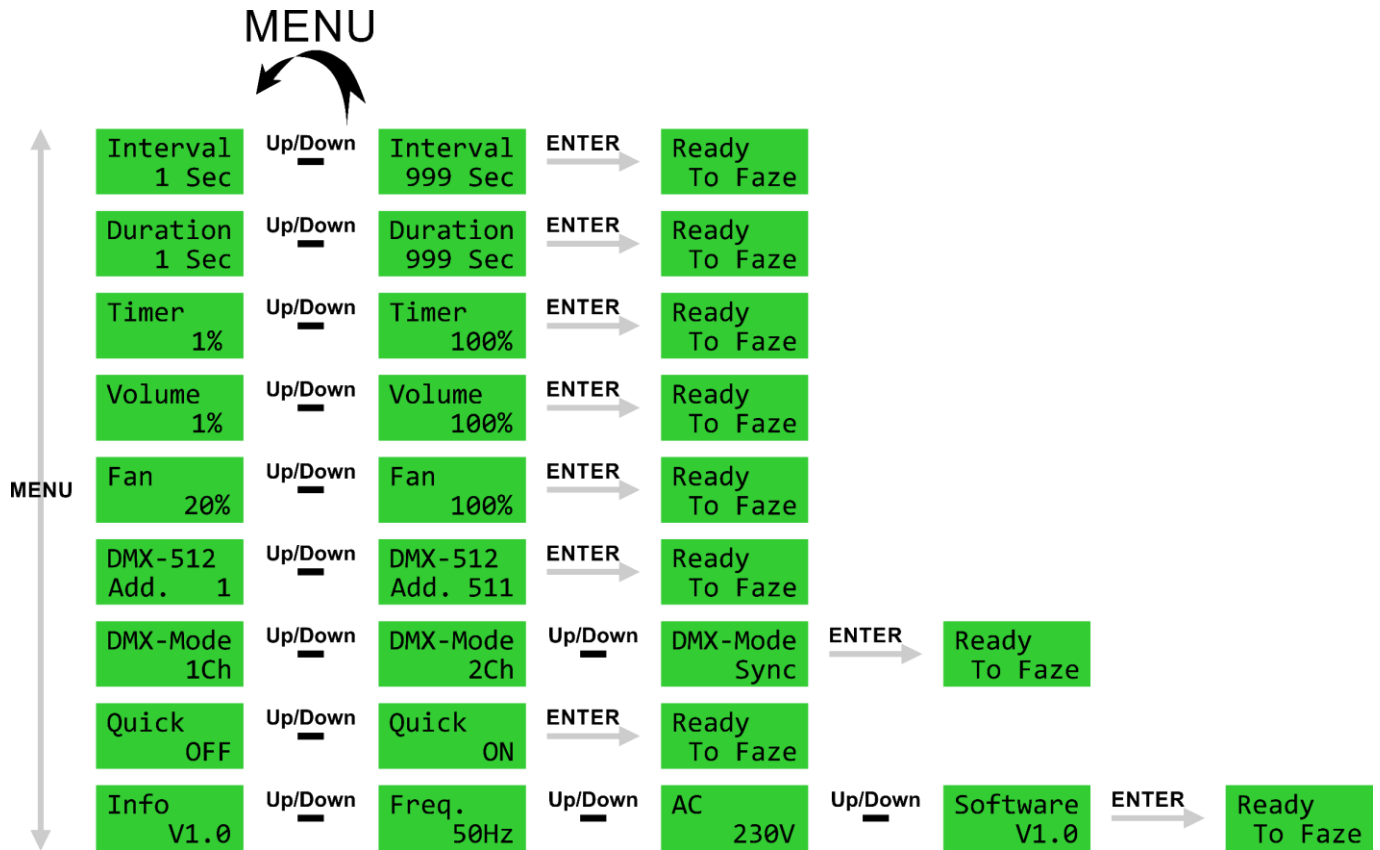

Main Menu Options

Plug the power cord into a grounded electrical outlet. The machine will now re-heat to the proper operating temperature. Once the proper temperature has been reached, the display will show the main menu.

Interval 1 Sec	Up/Down	Interval 999 Sec	Interval Time
Duration 1 Sec	Up/Down	Duration 999 Sec	Duration Time
Timer 1%	Up/Down	Timer 100%	Timer Output
Volume 1%	Up/Down	Volume 100%	Volume Output
Fan 20%	Up/Down	Fan 100%	Fan Speed
DMX-512 Add. 1	Up/Down	DMX-512 Add. 511	DMX Address
DMX-Mode 1Ch			DMX Mode
Quick OFF	Up/Down	Quick ON	Quick Mode
Info V1.0			Device Information

### 1. Interval Time

In this menu you can set the interval, i.e. the time between fog bursts.

- 01) Press the **MENU** button until the display shows INTERVAL.
- 02) Press the **UP/DOWN** buttons to set the interval time. The adjustment range is 1–999 seconds.
- 03) Press the **ENTER** button to confirm. The display will show READY TO FAZE.

### 2. Duration Time

In this menu you can set the fog burst duration.

- 01) Press the **MENU** button until the display shows DURATION.
- 02) Press the **UP/DOWN** buttons to set the duration time. The adjustment range is 1–999 seconds.
- 03) Press the **ENTER** button to confirm. The display will show READY TO FAZE.

### 3. Timer Output

In this menu you can set the output volume in Timer mode.

- 01) Press the **MENU** button until the display shows TIMER.
- 02) Press the **UP/DOWN** buttons to set the output volume. The adjustment range is 1–100 %, from low to high output.
- 03) Press the **ENTER** button to confirm. The display will show READY TO FAZE.

### 4. Volume Output

In this menu you can set the output volume in Volume mode.

- 01) Press the **MENU** button until the display shows VOLUME.
- 02) Press the **UP/DOWN** buttons to set the output volume. The adjustment range is 1–100 %, from low to high output.
- 03) Press the **ENTER** button to confirm. The display will show READY TO FAZE.

### 5. Fan Speed

In this menu you can set the fan speed.

- 01) Press the **MENU** button until the display shows FAN.
- 02) Press the **UP/DOWN** buttons to set the fan speed. The adjustment range is 20–100 %, from slow to fast.
- 03) Press the **ENTER** button to confirm. The display will show READY TO FAZE.

### 6. DMX Address

In this menu you can set the DMX address.

- 01) In main menu, press the **MENU** button until the display shows DMX-512.
- 02) Press the **UP/DOWN** buttons to select the required address. The adjustment range is 001–511.
- 03) Press the **ENTER** button to confirm. The display will show READY TO FAZE.

### 7. DMX Mode

In this menu you can set the DMX mode.

- 01) In main menu, press the **MENU** button until the display shows DMX-MODE.
- 02) Press the **UP/DOWN** buttons to choose one of the 3 DMX modes:

DMX-Mode  
1Ch

1-channel mode

DMX-Mode  
2Ch

2-channel mode

DMX-Mode  
Sync

Sync mode (1-channel mode)

- 03) Press the **ENTER** button to confirm. The display will show READY TO FAZE.

**8. Quick Mode**

In this menu you can set whether the device, upon power-up, will perform last action from before shutdown.

- 01) In main menu, press the **MENU** button until the display shows QUICK.
- 02) Press the **UP/DOWN** buttons to select ON/OFF.
- 03) Press the **ENTER** button to confirm. The display will show READY TO FAZE.
- 04) If you selected ON, upon power-up, the device will perform last action from before shutdown.

**9. Device Information**

In this menu you can view the device's parameters.

- 01) In main menu, press the **MENU** button until the display shows INFO.
- 02) Press the **UP/DOWN** buttons to view the following 3 parameters:

**Freq.**  
50Hz      Current frequency

**AC**  
230V      AC current voltage

**Software**  
V1.0      Software version

- 03) Press the **ENTER** button to confirm. The display will show READY TO FAZE.

**Manual Mode**

If you wish to use the WTF in Manual mode, unplug the DMX cable!  
Manual mode will not work if the DMX cable is connected!

**1. Timer Mode**

In this menu you can set Timer mode.

- 01) Set the interval and duration times. (See page 13 for more information.)
- 02) Set the timer output volume. (See page 13 for more information.)
- 03) Set the fan speed. (See page 13 for more information.)
- 04) Press the **ENTER** button to confirm. The display will show READY TO FAZE.
- 05) Press the **UP** button to activate Timer mode.
- 06) Press the **ENTER** button to stop Timer mode.

**2. Volume Mode**

In this menu you can set Volume mode.

- 01) Set the output volume. (See page 13 for more information.)
- 02) Set the fan speed. (See page 13 for more information.)
- 03) Press the **ENTER** button to confirm. The display will show READY TO FAZE.
- 04) Press the **DOWN** button to activate Volume mode.
- 05) Press the **ENTER** button to stop Volume mode.

**DMX Channels****1 Channel****Channel 1 – Faze effect**

0-5	Faze effect OFF, fan speed: 100 %
6-255	Faze effect ON: 1-100 %, fan speed: 100 %

**1 Channel (Sync)****Channel 1 – Faze effect**

0-5	Faze effect OFF, fan speed: 20 %
6-255	Faze effect ON: 1-100 %, fan speed: 21-100 %

**2 Channels****Channel 1 – Faze effect**

0-5	Faze effect OFF
6-255	Faze effect ON: 1-100 %

**Channel 2 – Fan speed**

0-5	Not functional
6-255	Fan speed: 20-100 %

**Maintenance**

The WTF-FZ1500 requires almost no maintenance. However, you should keep the unit clean. Disconnect the mains power supply and then wipe the cover with a damp cloth. Do not use alcohol or solvents. Do not immerse in liquid.

Keep connections clean. Disconnect electric power, and then wipe the connections with a damp cloth. Make sure connections are thoroughly dry before linking equipment or supplying electric power.

Remove dust from the air vents with an air compressor, vacuum or a soft brush (excessive dust, liquid and dirt built up will degrade performance and may cause overheating). Run the machine on monthly basis in order to achieve best performance and output condition.

Do not allow the fog liquid to become contaminated. Always close the fog liquid tank immediately after adding the fog liquid to the tank.

**Performance Note:**

- Fog machines develop condensation around the output nozzle. Because this may result in moisture accumulation on the surface below the output nozzle, consider this condensation when installing your machine. Fog machines may occasionally sputter small amounts of fog, during operation and/or after being turned off.
- WTF-FZ1500 faze machine has a heating cycle after bursts of fog so the machine stops fogging for a short period in order to heat up. During this time no fog can be produced.
- Only use the recommended fog liquids.

**Cleaning**

Before storing the WTF, it needs to be cleaned.

- 01) Whenever the display shows READY TO FAZE, press and hold down the **ENTER** button for 4 seconds.
- 02) The display will show CLEANING. The process will take 180 seconds.
- 03) The display will show CLEANING FINISH.
- 04) Unplug the device.

**Replacing the Fuse**

You do not have to replace the fuse on this device as the fuse is automatic.

- 01) In case of a power surge, short-circuit or inappropriate power supply, press the breaker button **(07)** and the device will function normally.
- 02) Try to determine the cause of the problem, so that the situation does not happen in the future.



## **Troubleshooting**

---

This troubleshooting guide is meant to help solve simple problems.

Always monitor the fog tank liquid level when operating the device. Running the device without fog liquid can cause permanent damage to the device.

If a problem occurs, carry out the steps below in sequence until a solution is found. Once the unit operates properly, do not carry out following steps.

If the WTF does not operate properly, refer servicing to a technician.

01) If you experience low output or no output at all, unplug immediately.

02) Check the fog liquid level and the power from the wall.

03) Check if the tank hose is properly attached to the fog liquid tank.

04) Check the fuse. See page 15.

05) If all of the above appears to be O.K., plug the unit in again.

06) If you are unable to determine the cause of the problem, do not simply continue, as this may damage the device.

07) Return the WTF to your Showtec dealer.

**No Response to DMX**

Suspect the DMX cable or connectors, a controller malfunction, a light effect DMX card malfunction.

- 01) Check the DMX setting. Make sure that DMX addresses are correct.
- 02) Check the DMX cable: Unplug the unit; change the DMX cable; then reconnect to electrical power. Try your DMX control again.
- 03) Determine whether the controller or light effect is at fault. Does the controller operate properly with other DMX products? If not, take the controller in for repair. If so, take the DMX cable and the light effect to a qualified technician.

<b>Problem</b>	<b>Probable cause(s)</b>	<b>Remedy</b>
One or more fixtures do not function at all.	No power to the fixture.	<ul style="list-style-type: none"> <li>● Check if power is switched on and cables are plugged in.</li> </ul>
	Circuit breaker is active.	<ul style="list-style-type: none"> <li>● Reset the circuit breaker.</li> </ul>
Fixtures reset correctly, but all respond erratically or not at all to the controller.	The controller is not connected.	<ul style="list-style-type: none"> <li>● Connect controller.</li> </ul>
	3-pin XLR Out of the controller does not match XLR In of the first fixture on the link (i.e. signal is reversed).	<ul style="list-style-type: none"> <li>● Install a phase reversing cable between the controller and the first fixture on the link.</li> </ul>
Fixtures reset correctly, but some respond erratically or not at all to the controller.	Poor data quality.	<ul style="list-style-type: none"> <li>● Check data quality. If much lower than 100 percent, the problem may be a bad data link connection, poor quality or broken cables, missing termination plug, or a defective fixture disturbing the link.</li> </ul>
	Bad data link connection.	<ul style="list-style-type: none"> <li>● Inspect connections and cables. Correct poor connections. Repair or replace damaged cables.</li> </ul>
	Data link not terminated with 120 Ohm termination plug.	<ul style="list-style-type: none"> <li>● Insert termination plug in output jack of the last fixture on the link.</li> </ul>
	Incorrect addressing of the fixtures.	<ul style="list-style-type: none"> <li>● Check address setting.</li> </ul>
	One of the fixtures is defective and disturbs data transmission on the link.	<ul style="list-style-type: none"> <li>● Bypass one fixture at a time until normal operation is regained: unplug both connectors and connect them directly together.</li> <li>● Have the defective fixture serviced by a qualified technician.</li> </ul>
	3-pin XLR Out on the fixtures does not match (pins 2 and 3 reversed).	<ul style="list-style-type: none"> <li>● Install a phase-reversing cable between the fixtures or swap pin 2 and 3 in the fixture, that behaves erratically.</li> </ul>
No fog output.	Fixture is too hot.	<ul style="list-style-type: none"> <li>● Allow fixture to cool.</li> <li>● Make sure air vents are not blocked.</li> <li>● Turn up the air conditioning.</li> </ul>
	The device is damaged.	<ul style="list-style-type: none"> <li>● Disconnect fixture and return to your dealer.</li> </ul>
	The power supply settings do not match local AC voltage and frequency.	<ul style="list-style-type: none"> <li>● Disconnect fixture. Check settings and correct if necessary.</li> </ul>

## Product Specifications

Model:	WTF-FZ1500
Input voltage:	220–240 V AC, 50/60 Hz
Power consumption:	1450 W
Heater:	1450 W
Output:	6000 cu.ft/min
Heating time:	1,5 minutes
Tank capacity:	5 L
Liquid consumption:	5,1 ml/min (full output)
Control modes:	Manual, DMX-512
DMX mode:	1, 1, 2 channels
Color:	Black
Housing:	Metal & flame-retardant plastic
Data connection:	3-pin/5-pin XLR IN/OUT
Power connection:	Fixed Schuko power cable (1,8 m)
IP rating:	IP20
Dimensions:	438 x 395 x 260 mm (LxWxH)
Weight:	13,3 kg
Max. ambient temperature $t_a$ :	40 °C
Max. housing temperature $t_b$ :	70 °C
<b>Minimum distance:</b>	
Minimum distance from surfaces:	0,5 m
Minimum distance from objects:	0,5 m

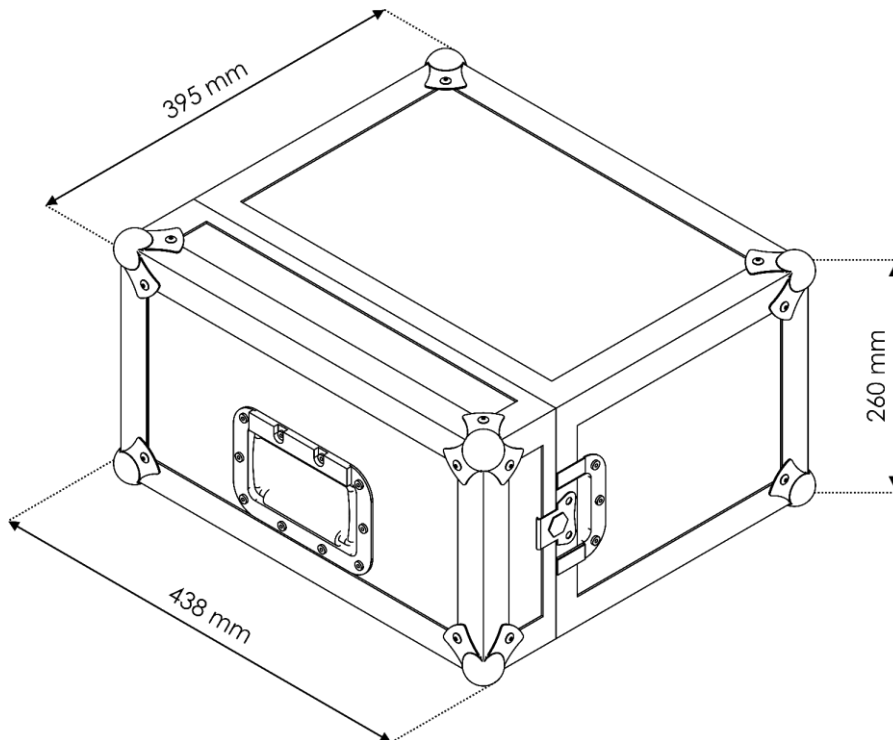

Design and product specifications are subject to change without prior notice.



Website: [www.Showtec.info](http://www.Showtec.info)  
 Email: [service@highlite.com](mailto:service@highlite.com)



©2020 Showtec