

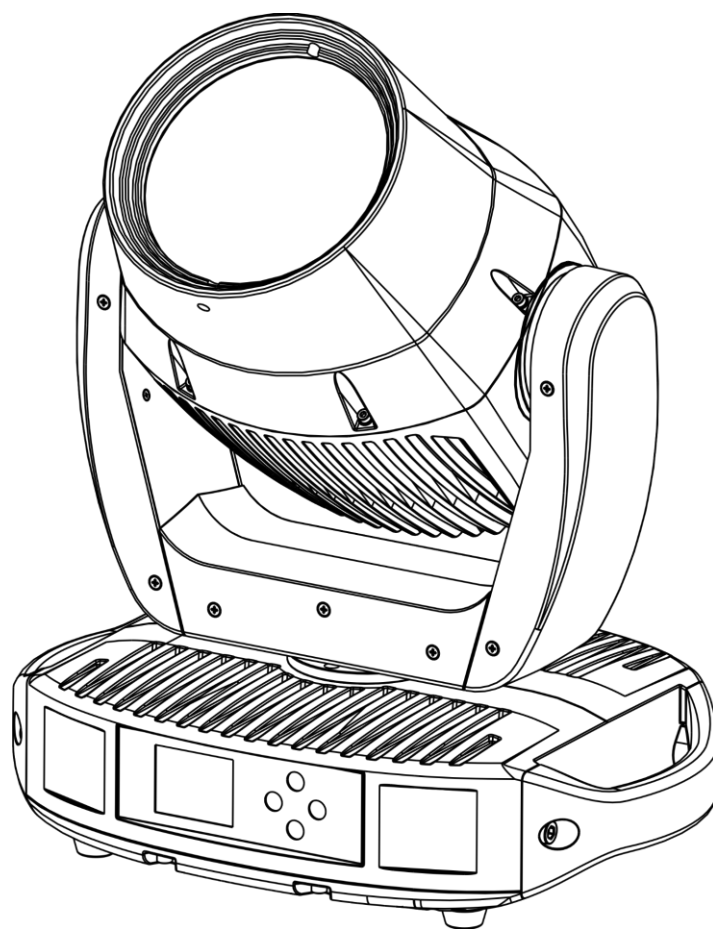

MANUAL



ENGLISH

Polar 100 Beam IP65 Moving Head V2

Order code: 40100

Table of contents

Warning	3
Safety Instructions	3
Operating Determinations	5
Rigging	5
Connection with the Mains	7
Return Procedure	7
Claims	7
Description of the Device	8
Features	8
Photometric Diagram	8
Front View	9
Back View	9
Installation	10
Setup and Operation	10
Multiple Fixtures Power Linking	10
Control Modes	10
One Polar (Auto Program, Custom Programs)	10
One Polar (Manual)	10
Multiple Polars (Master/Slave Control)	11
Multiple Polars (DMX/RDM Control)	12
Multiple Polars (Art-Net/sACN Control)	13
Multiple Polars (Wireless DMX Control)	14
Connect the Polar to the Wireless DMX Signal Transmitter	15
Disconnect the Polar from the Wireless DMX Signal Transmitter	15
Connecting to a Network	16
Art-Net Settings	16
sACN Settings	16
How to Make a Data Cable	17
Fixture Linking	18
Data Cabling	18
Control Panel	19
DMX Addressing	19
Menu Overview	20
Start-up	24
No Reset Start-up	24
Main Menu Options	25
1. DMX Address	25
2. Person (DMX Channel Modes)	25
3. Run Mode	25
4. Option	26
4.1. Dimmer	27
4.2. Display Lock	27
4.3. Settings	27
4.3.1. Recovery	27
4.3.2. Clean Edit 1	27
4.3.3. Clean Edit 2	27
4.3.4. WDMX Hide	27
4.4. Network	28
4.4.1. IP Mode	28
4.4.2. Custom IP	28
4.5. Signal	29
5. Edit	29
6. Manual	30
6.1. Channel	31

6.2. Reset31
7. Info.....32
7.1. System Error.....32
8. Service33
DMX Channels34
12 Channels (Basic)34
15 Channels (Standard)37
18 Channels (Extended)40

Maintenance43
Replacing the Fuse43
Gobo Wheel and Color Wheel44

Troubleshooting44
No Light44
No Response to DMX.....44

Product Specifications46

Dimensions.....47

Notes.....48

Warning



**For your own safety, please read this user manual carefully
before your initial start-up!**



Unpacking Instructions

Immediately upon receiving this product, carefully unpack the carton and check the contents to ensure that all parts are present, and have been received in good condition. Notify the dealer immediately and retain packing material for inspection if any parts appear damaged from shipping or the carton itself shows signs of mishandling. Save the carton and all packing materials. In the event that a fixture must be returned to the factory, it is important that the fixture will be returned in the original factory box and packing.

Your shipment includes:

- Showtec Polar 100 Beam IP65 Moving Head
- Schuko to PowerCON True1 power cable (1,5 m)
- 2 x quick-lock brackets
- User manual

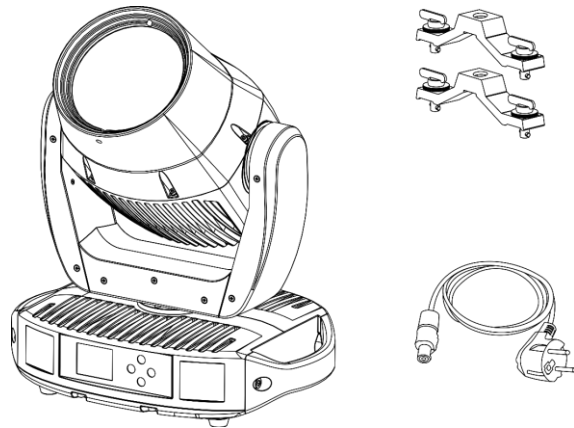

LED Expected Lifespan

LEDs gradually decline in brightness over time. HEAT is the dominant factor that leads to the acceleration of this decline. Packaged in clusters, LEDs exhibit higher operating temperatures than in ideal or singular optimum conditions. For this reason, when all color LEDs are used at their fullest intensity, life of the LEDs is significantly reduced. If improving the lifespan is of higher priority, place care in providing for lower operational temperatures. This may include climatic-environmental and the reduction of overall projection intensity.

Safety Instructions

Every person involved with the installation, operation and maintenance of this device has to:

- be qualified
- follow the instructions of this manual



**CAUTION! Be careful with your operations.
With a dangerous voltage you can suffer
a dangerous electric shock when touching the wires!**



Before the initial start-up, please make sure that there is no damage caused by transportation. Should there be any, consult your dealer and do not use the device.

To maintain perfect condition and to ensure a safe operation, it is absolutely necessary for the user to follow the safety instructions and warning notes contained in this manual.

Please consider that damages caused by manual modifications to the device are not subject to warranty.

This device contains no user-serviceable parts. Refer servicing to qualified technicians only.

IMPORTANT:

The manufacturer will not accept liability for any resulting damages caused by the non-observance of this manual or any unauthorized modification to the device.

- Never let the power cord come into contact with other cables! Handle the power cord and all connections with the mains with particular caution!
- Never modify, bend, mechanically strain, put pressure on, pull or heat up the power cord.
- Never strain the cable. There must always be sufficient cable going to the device. Otherwise, the cable will be damaged, which can cause serious damage.
- Never remove warning or informative labels from the unit.
- Never use anything to cover the ground contact.
- Never lift the device holding it by the projector-head, as the mechanics may be damaged. Always hold the device by the transport handles.
- Never place any material over the LEDs or lens.
- Never look directly into the light source.
- Never leave any cables lying around.
- Never use the device during thunderstorms, unplug the device immediately.
- Never leave various parts of the packaging (plastic bags, polystyrene foam, nails, etc.) within children's reach, as they are potential sources of danger.
- Do not insert objects into air vents.
- Do not open the device and do not modify the device.
- Do not connect this device to a dimmer pack.
- Do not switch the device on and off in short intervals, as this will reduce the device's life.
- Do not touch the device's housing bare-handed during its operation (housing becomes very hot). Allow the device to cool for at least 5 minutes before handling.
- Do not shake the device. Avoid brute force when installing or operating the device.
- Only operate the device after having checked if the housing is firmly closed and all screws are tightly fastened.
- Only operate the device after having familiarized with its functions.
- Avoid flames and do not put close to flammable liquids or gases.
- Always keep the case closed while operating.
- Always allow a free air space of at least 1,3 m around the unit for ventilation.
- Always disconnect power from the mains, when device is not used or before cleaning! Only handle the power cord holding it by the plug. Never pull out the plug by tugging the power cord.
- Make sure that the device is not exposed to extreme heat, moisture or dust.
- Make sure that the available voltage is not higher than stated on the rear panel.
- Make sure that the power cord is never crimped or damaged. Check the device and the power cord from time to time.
- Make sure that the core diameter of extension cords and power cords is sufficient for the required power consumption of the device.
- If the lens or LEDs are obviously damaged, they need to be replaced to prevent their functions from being impaired, due to cracks or deep scratches.
- If the external cable is damaged, it has to be replaced by a qualified technician.
- If device was dropped or struck, disconnect mains power supply immediately. Have a qualified engineer inspect for safety before operating.
- If the device has been exposed to drastic temperature fluctuation (e.g. after transportation), do not switch it on immediately. The arising condensation water might damage your device. Leave the device switched off until it has reached room temperature.
- If your Showtec device fails to work properly, discontinue the use immediately. Pack the unit securely (preferably in the original packing material), and return it to your Showtec dealer for service.
- For adult use only. The device must be installed beyond the reach of children. Never leave the unit running unattended.
- Never attempt to bypass the thermostatic switch or fuses.
- For replacement use fuses of same type and rating only.
- The user is responsible for correct positioning and operating of the device. The manufacturer will not accept liability for damages caused by the misuse or incorrect installation of this device.
- This device falls under protection class I. Therefore it is essential to connect the yellow/green conductor to earth.

- Repairs, servicing and electric connection must be carried out by a qualified technician.
- WARRANTY: Till one year after date of purchase.

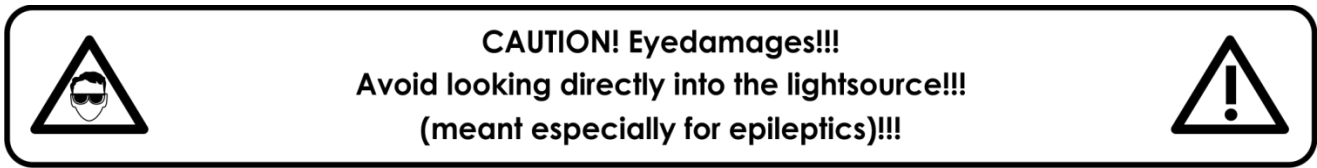

Operating Determinations

- This device is not designed for permanent operation. Consistent operation breaks will ensure that the device will serve you for a long time without defects.
- The minimum distance between light output and the illuminated surface must be bigger than 1,3 m.
- To eliminate wear and improve lifespan, during periods of non-use, completely disconnect from power via breaker or by unplugging.
- The maximum ambient temperature $t_a = 40\text{ °C}$ must never be exceeded.
- The relative humidity must not exceed 50 % with an ambient temperature of 40 °C.
- If this device is operated in any other way than the one described in this manual, the product may suffer damages and the warranty becomes void.
- Any other operation may lead to dangers like short-circuit, burns, electric shock, crash, etc.

You endanger your own safety and the safety of others!

Rigging

Please follow the European and national guidelines concerning rigging, trussing and all other safety issues.

Do not attempt the installation yourself!

Always let the installation be carried out by an authorized dealer!

Procedure:

- If the Polar is lowered from the ceiling or high joists, professional trussing systems have to be used.
- Use clamps to mount the Polar with the mounting brackets to the trussing system.
- The Polar must never be fixed swinging freely in the room.
- The installation must always be secured with a safety attachment, e.g. an appropriate safety net or safety cable.
- When rigging, derigging or servicing the Polar, always make sure, that the area below the installation site is secured and that there are not any unauthorized people around.

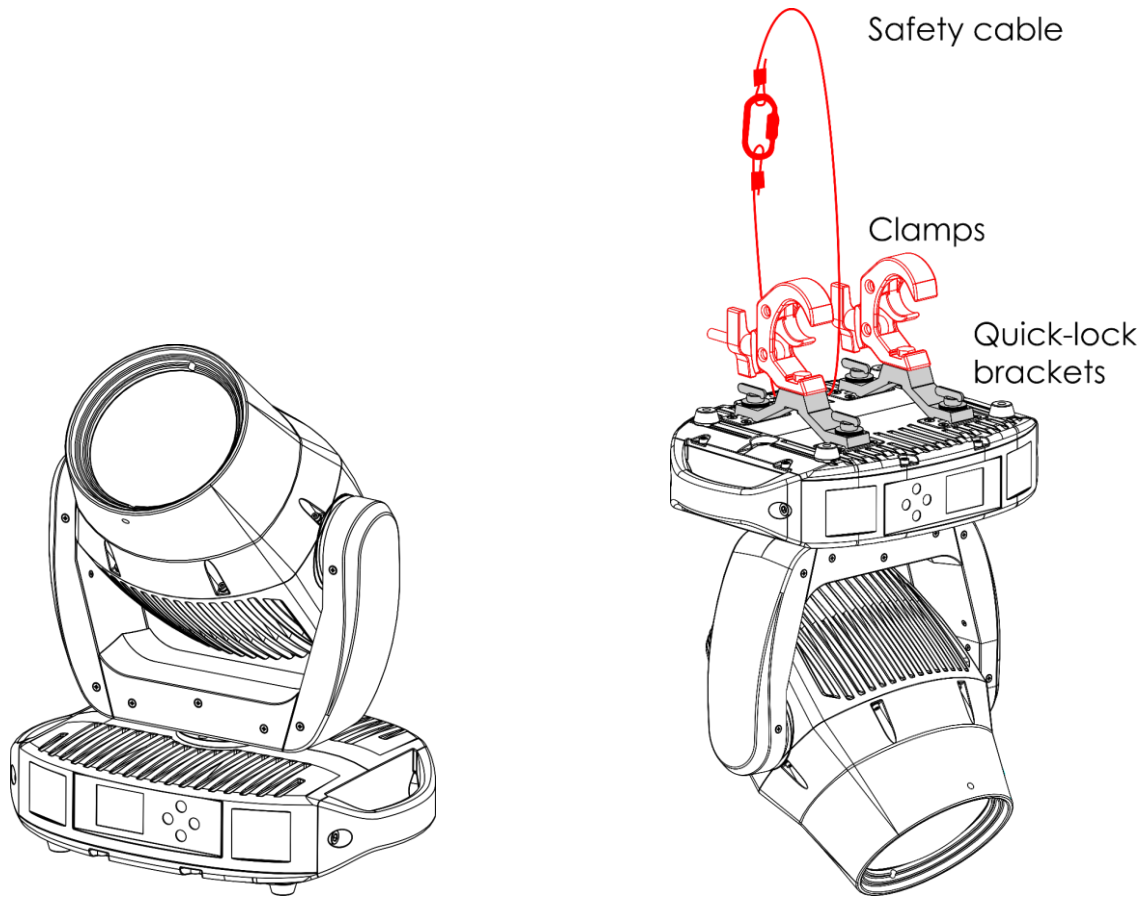

Fig. 01

The Polar can be placed on a flat stage floor or mounted to any kind of truss with the quick-lock brackets and clamps.

The quick-lock brackets can be positioned on the base of the Polar in two ways, as shown on Fig. 02.

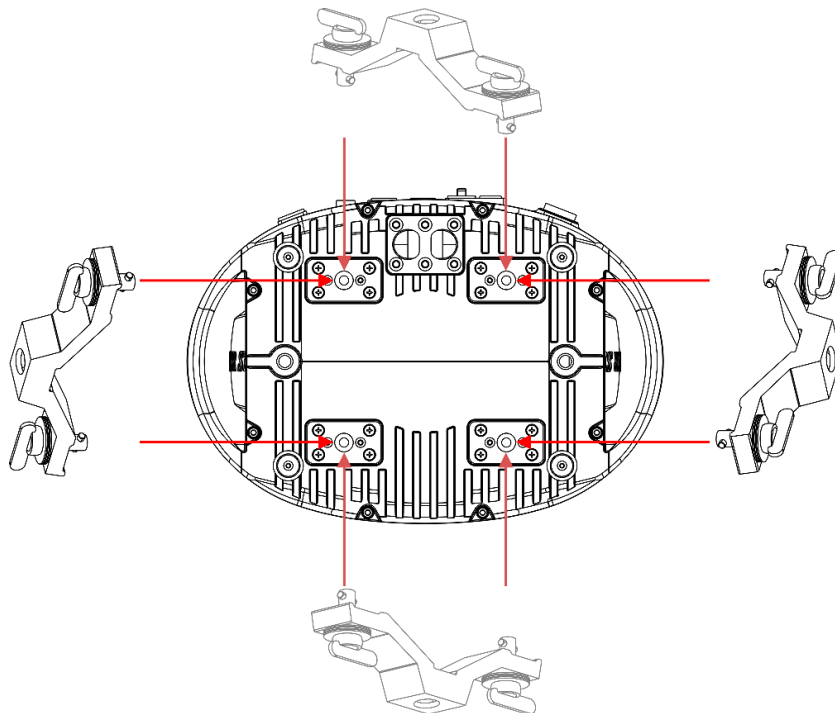



Fig. 02

Improper installation can cause serious injuries and/or damage of property!

Connection with the Mains

Connect the device to the mains with the power-plug.
Always check if the right color cable is connected to the right place.

International	EU Cable	UK Cable	US Cable	Pin
L	BROWN	RED	YELLOW/COPPER	PHASE
N	BLUE	BLACK	SILVER	NEUTRAL
	YELLOW/GREEN	GREEN	GREEN	PROTECTIVE GROUND

Make sure that the device is always properly connected to the earth!

Improper installation can cause serious injuries and/or damage of property!



Return Procedure

Returned merchandise must be sent prepaid and in the original packing, call tags will not be issued. Package must be clearly labeled with a Return Authorization Number (RMA number). Products returned without an RMA number will be refused. Highlite will not accept the returned goods or any responsibility. Call Highlite 0031-455667723 or mail aftersales@highlite.com and request an RMA prior to shipping the fixture. Be prepared to provide the model number, serial number and a brief description of the cause for the return. Be sure to properly pack fixture, any shipping damage resulting from inadequate packaging is the customer's responsibility. Highlite reserves the right to use its own discretion to repair or replace product(s). As a suggestion, proper UPS packing or double-boxing is always a safe method to use.

Note: If you are given an RMA number, please include the following information on a piece of paper inside the box:

- 01) Your name
- 02) Your address
- 03) Your phone number
- 04) A brief description of the symptoms

Claims

The client has the obligation to check the delivered goods immediately upon delivery for any shortcomings and/or visible defects, or perform this check after our announcement that the goods are at their disposal. Damage incurred in shipping is the responsibility of the shipper; therefore the damage must be reported to the carrier upon receipt of merchandise.

It is the customer's responsibility to report and submit claims with the shipper in the event that a fixture is damaged due to shipping. Transportation damage has to be reported to us within one day after receipt of the delivery.

Any return shipment has to be made post-paid at all times. Return shipments must be accompanied with a letter defining the reason for return shipment. Non-prepaid return shipments will be refused, unless agreed otherwise in writing.

Complaints against us must be prepared in writing or sent by fax within 10 working days after receipt of the invoice. After this period complaints will not be handled anymore.

Complaints will only then be considered if the client has so far complied with all parts of the agreement, regardless of the agreement from which the obligation is resulting.

Description of the Device

Features

The Polar100 Beam is a moving head with high output and great effects.

- Input voltage: 100–240 V AC, 50/60 Hz
- Power consumption: 180 W
- Light source: 100 W LED Module
- Light output: 170000 Lux @ 5 m
- Dimmer: 0–100 % (16 bit)
- Strobe: 0–25 Hz
- Beam angle: 1,7°
- Focus: Motorized linear focus
- Control protocol: DMX-512, Art-Net, sACN, RDM, W-DMX
- Control personality: 12 channels (Basic), 15 channels (Standard), 18 channels (Extended)
- Pan: 0°–540°
- Tilt: 0°–270°
- Pan/Tilt resolution: 8–16 bit
- Special: Pan/Tilt movement blackout, user selectable Pan/Tilt ranges, reverse Pan/Tilt movement
- Control modes: Stand alone, Manual, Master/Slave, DMX-512, Art-Net/sACN, W-DMX
- Color wheel: 9 dichroic filters + white
- Rotating gobo wheel: 8 rotating gobos + open
- Color functions: Rainbow flow effect, split colors
- Gobo functions: Gobo flow effect, gobo shake, gobo bounce, bidirectional rotation
- Prism: 1 x 5-facet linear prism and 1 x 24-facet circular prism
- Prism functions: Bidirectional rotation, adjustable speed, prism overlay
- Housing: Flame-retardant plastic, die-cast aluminum
- Color: Black
- Cooling: Natural radiation
- IP rating: IP-65
- Connections: IP-65 rated power connectors True1 IN/OUT, IP-65 rated 5-pin DMX IN/OUT connectors, 2 x IP-65 rated RJ45 connectors
- Fuse: T6,3 A/250 V
- Dimensions: 482 x 410 x 295 mm (L x W x H)
- Weight: 19,7 kg

Photometric Diagram

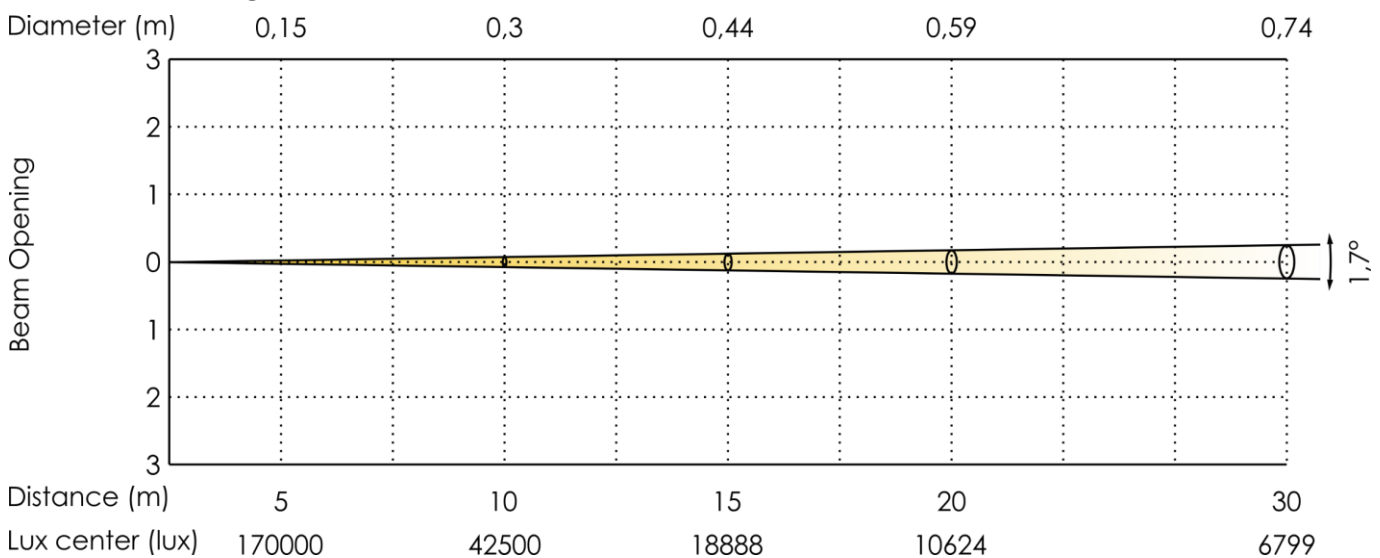

Fig. 03

Front View

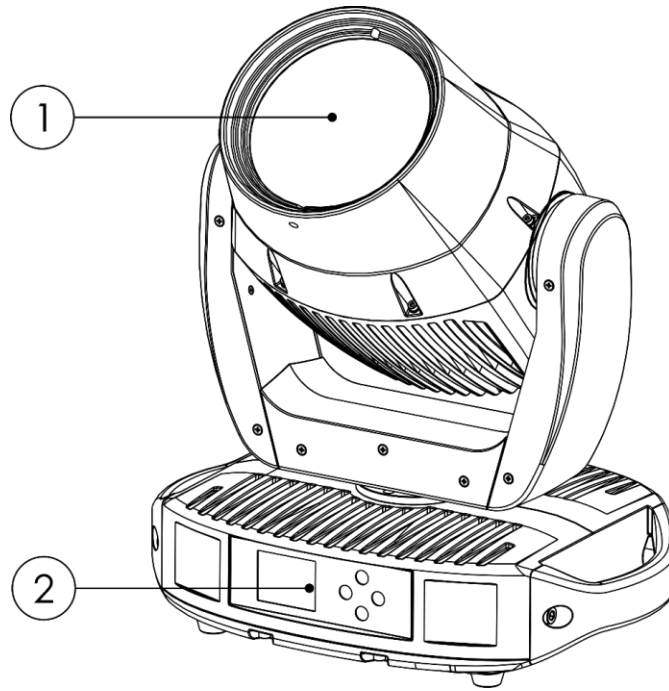

Fig. 04

- 01) 100 W LED Module
- 02) Control panel: LCD display and control buttons

Back View

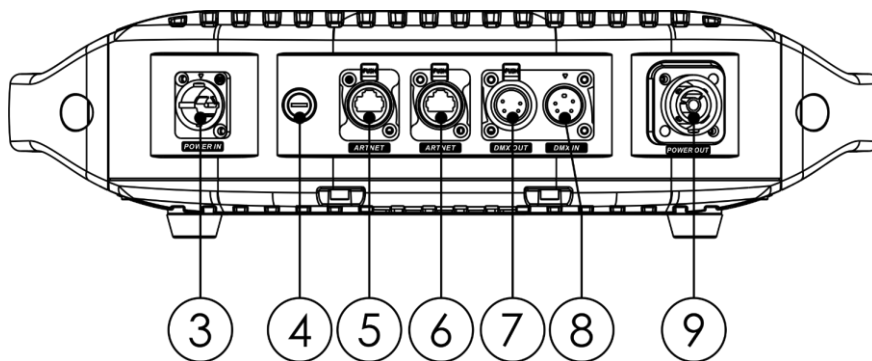

Fig. 05

- 03) IP-65 rated power connector True1 IN
- 04) Fuse T6,3 A/250 V
- 05) IP-65 rated RJ45 connector
- 06) IP-65 rated RJ45 connector
- 07) IP-65 rated 5-pin DMX signal connector OUT
- 08) IP-65 rated 5-pin DMX signal connector IN
- 09) IP-65 rated power connector True1 OUT

Installation

Remove all packing materials from the Polar 100 Beam IP65 Moving Head. Check if all foam and plastic padding is removed. Connect all cables.

Do not supply power before the whole system is set up and connected properly.

Always disconnect from electric mains power supply before cleaning or servicing.

Damages caused by non-observance are not subject to warranty.

Setup and Operation

Follow the directions below, as they pertain to your preferred operation mode.

Before plugging the unit in, always make sure that the power supply matches the product specification voltage. Do not attempt to operate a 110 V specification product on 240 V power, or vice versa.

Connect the device to the main power supply.

Multiple Fixtures Power Linking

The Polar 100 Beam IP65 Moving Head supports power linking. Power can be relayed to another device via the power OUT connector. Note that the input and the output connectors have different designs: one type cannot be connected to the other.

To link fixtures in a chain, a hard usage cable with appropriate cable jacket must be used. Power linking cables are available for purchase from Highlife International.

To prevent power overload and damage to the fixture, do not link more fixtures in one chain than recommended. After you have reached the maximum number of fixtures, use a new power outlet.



Maximum recommended number of fixtures on a power link @ 110 V: 6 fixtures

Maximum recommended number of fixtures on a power link @ 240 V: 10 fixtures

Control Modes

There are 6 modes:

- Stand-alone (Auto program, Custom programs)
- Manual
- Master/Slave
- DMX-512 (12 CH, 15 CH, 18 CH)
- Art-Net/sACN (12 CH, 15 CH, 18 CH)
- W-DMX (12 CH, 15 CH, 18 CH)

One Polar (Auto Program, Custom Programs)

- 01) Fasten the effect light to a firm trussing or mount it on flat surface. Leave at least 1,3 m on all sides for air circulation.
- 02) Secure the device with a safety cable (order code 70454 / 70456).
- 03) Plug the end of the electric mains power cord into a proper electric power supply socket.
- 04) When the Polar is not connected with a DMX cable, it functions as a stand-alone device.
- 05) Please see **3. Run Mode** on page 25 for more information.

One Polar (Manual)

- 01) Fasten the effect light to a firm trussing or mount it on flat surface. Leave at least 1,3 m on all sides for air circulation.
- 02) Secure the device with a safety cable (order code 70454 / 70456).
- 03) Plug the end of the electric mains power cord into a proper electric power supply socket.
- 04) When the Polar is not connected with a DMX cable, it functions as a stand-alone device.
- 05) Please see **6. Manual** on page 30 for more information.

Multiple Polars (Master/Slave Control)

- 01) Fasten the effect light onto firm trussing or mount it on flat surface. Leave at least 1,3 m on all sides for air circulation.
- 02) Secure the device with a safety cable (order code 70454 / 70456).
- 03) Use a 5-pin DMX cable to connect the Polar to other devices.

The pins:



1. Earth
2. Signal (-)
3. Signal (+)
4. N/C
5. N/C

- 04) Link the units as shown in Fig. 06. Connect the first unit's DMX "out" socket with the second unit's "in" socket, using a DMX cable. Repeat this process to link the rest of the units. The first connected device will be automatically recognized as master device. To upload custom programs from the master device to the slave devices, see **4. Option** on page 26.
- 05) Supply electric power: Plug electric mains power cords into each unit's power IN socket, then plug the other end of the mains power cord into proper electric power supply sockets, starting with the first unit. Do not supply power before the whole system is set up and connected properly.

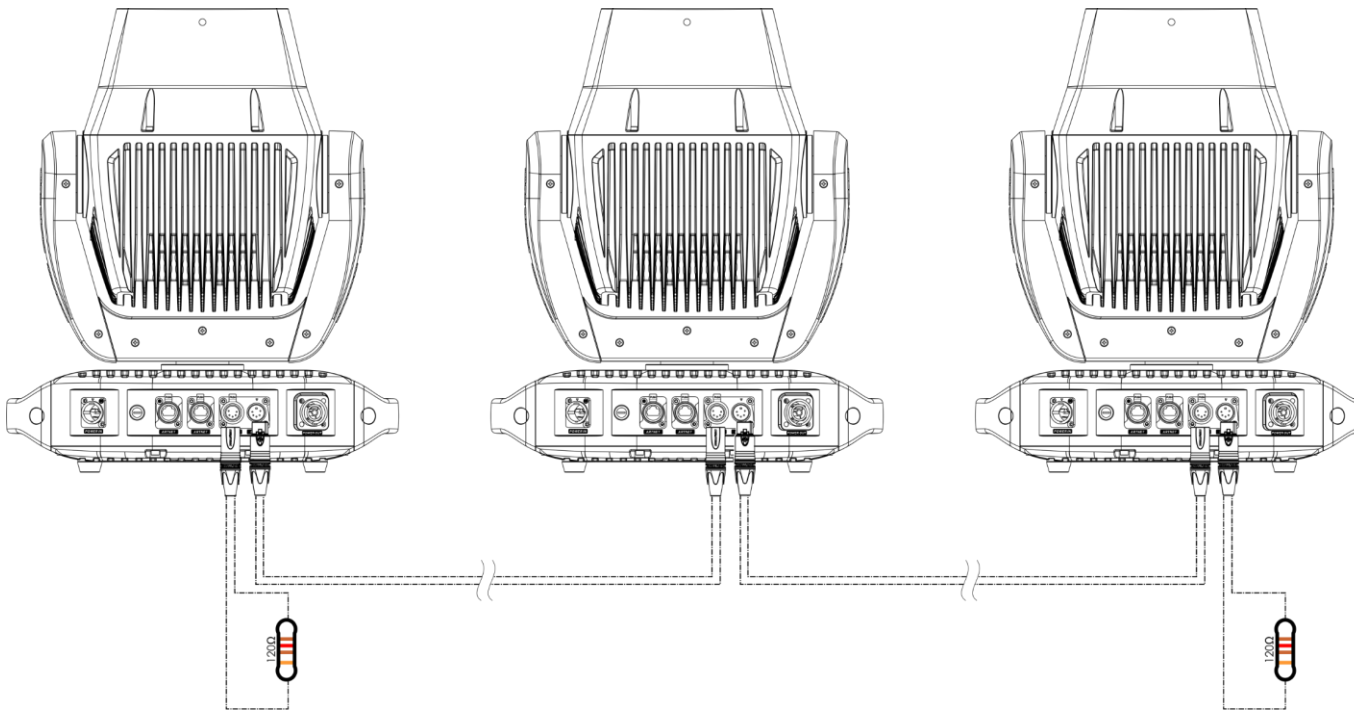
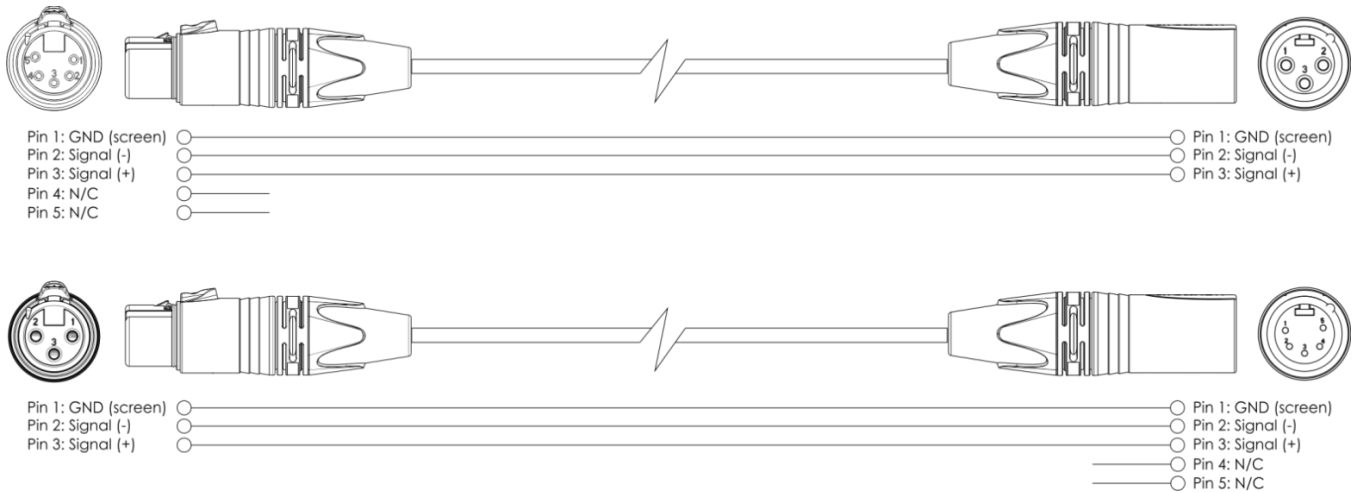

Fig. 06

Note: Link all cables before connecting electric power

Multiple Polars (DMX/RDM Control)

- 01) Fasten the effect light to a firm trussing or mount it on flat surface. Leave at least 1,3 m on all sides for air circulation.
- 02) Secure the device with a safety cable (order code 70454 / 70456).
- 03) Use a 5-pin DMX cable to connect the Polar and other devices.



- 04) Link the units as shown in Fig. 07. Connect a light controller to the first unit's DMX "in" socket, using a DMX cable. Connect the first unit's "out" socket with the second unit's "in" socket, using a DMX cable. Repeat this process to link the rest of the units.
- 05) Supply electric power: Plug electric mains power cords into each unit's power IN socket, then plug the other end of the mains power cord into proper electric power supply sockets, starting with the first unit. Do not supply power before the whole system is set up and connected properly.

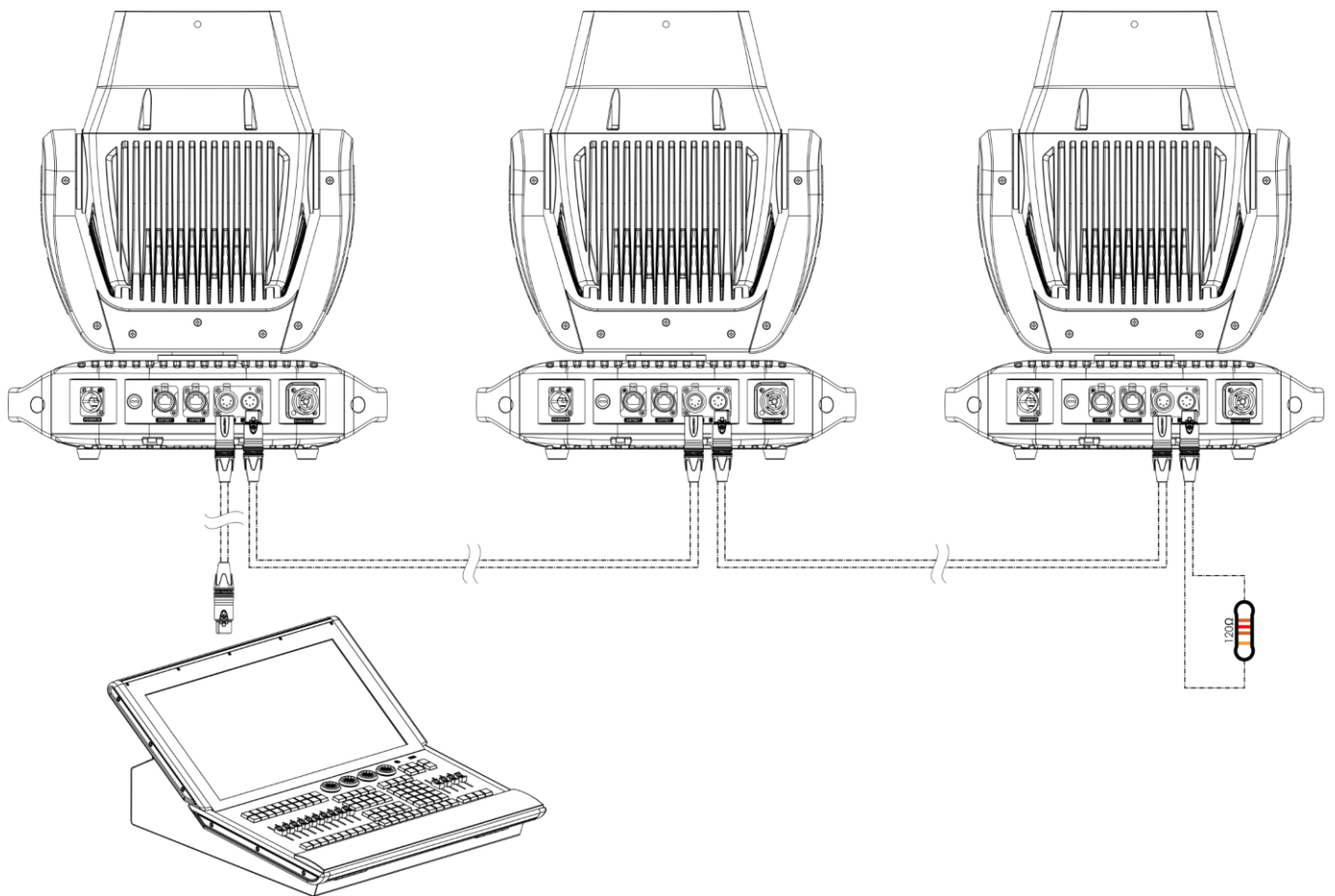

Fig. 07

Note: Link all cables before connecting electric power

Multiple Polars (Art-Net/sACN Control)

- 01) Fasten the effect light to a firm trussing or mount it on flat surface. Leave at least 1,3 m on all sides for air circulation.
- 02) Secure the device with a safety cable (order code 70454 / 70456).
- 03) Use a CAT-5/CAT-6 cable to connect the Polar and other devices.
- 04) Connect your computer with installed Art-Net software to the first device's RJ45 "in" socket.
- 05) Link the units as shown in Fig. 08. Connect the first unit's RJ45 "out" socket with the second unit's "in" socket, using a CAT-5/CAT-6 cable. Repeat this process to link the rest of the units.
- 06) Supply electric power: Plug electric mains power cords into each unit's power IN socket, then plug the other end of the mains power cord into proper electric power supply sockets, starting with the first unit. Do not supply power before the whole system is set up and connected properly.

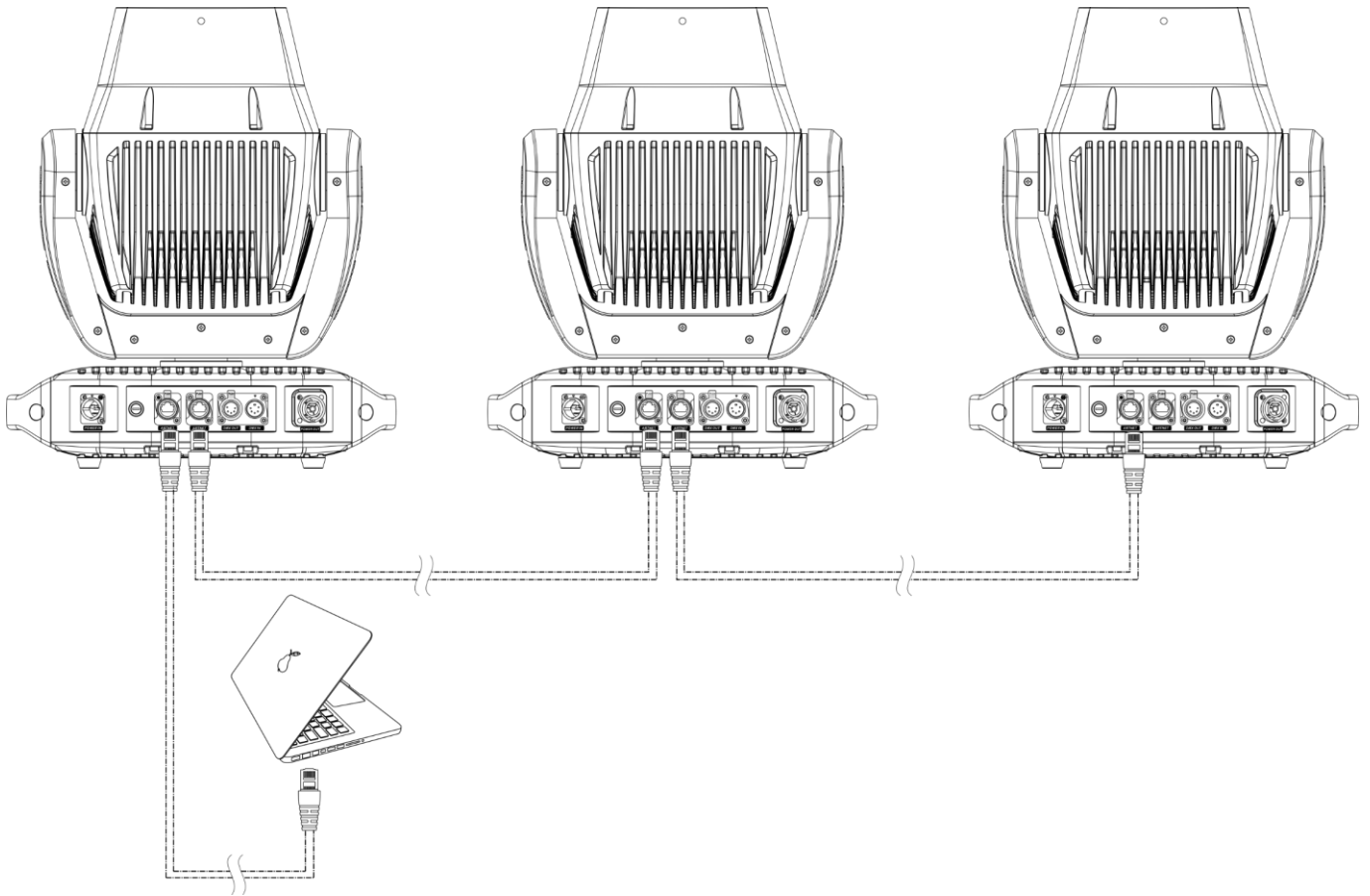

Fig. 08

Note: Link all cables before connecting electric power

Note: The Polar 100 Beam supports Art-Net to DMX, which means that you can connect the first device to your computer using a CAT-5/CAT-6 cable and the rest of the devices can be linked using a DMX cable. For more information, see **3. Run Mode** on page 25.

Multiple Polars (Wireless DMX Control)

- 01) Install multiple Polars at the desired positions (maximum distance to transceiver: 250 m).
- 02) In order for the Polars to receive a wireless DMX signal properly, activate W-DMX on all Polars (see **4.5. Signal** on page 29 for more information).
- 03) Pair the wireless signal transmitter with multiple Polars. In order to create a wireless connection, please read the manual of your wireless signal transmitter.
- 04) Use a DMX cable to connect the transmitter to a suitable light controller.

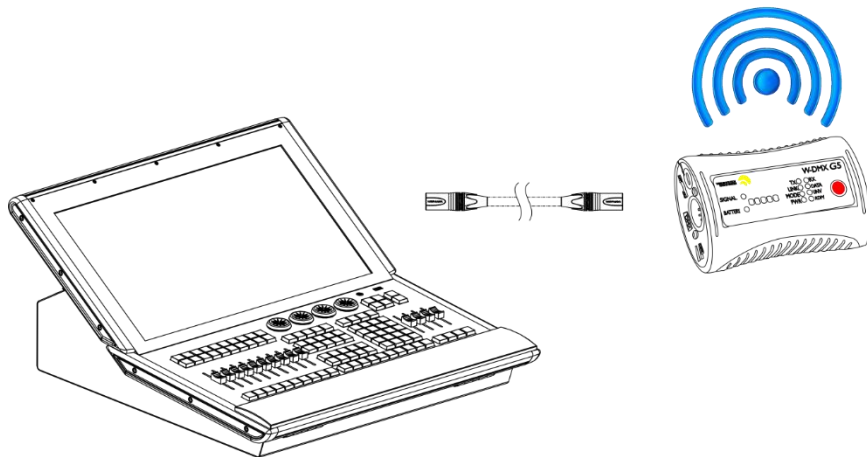

Use the Wireless DMX MicroBox F-1 G5 Transceiver (50175).

Fig. 09

Sweden 2.4 GHz Wireless communication module

Communication distance:	Depending on the transmitting power or transmitter module
Test conditions:	W-DMX TRx Transmitter module, 2 dBi Antenna, transmitting power 20 dBm (100 mW)
Range indoor:	60 m (approx. through three concrete walls)
Range outdoor:	250 m

Wireless DMX Connection

The wireless receiving module "Nano G5 Receiver, 2.4 GHz", provided by the Swedish WIRELESS SOLUTION, only has a 2.4 GHz wireless signal receiving function. In order to match the wireless signal, please use the [50175](#) W-DMX MicroBox F-1 G5 Transceiver by WIRELESS SOLUTION.



The Polar cannot receive a wireless DMX signal and a DMX cable signal at the same time.



Connect the Polar to the Wireless DMX Signal Transmitter

Enable W-DMX for the device and select the W-DMX option as control mode. See **4.5. Signal** on page 29 for more information.

The Polar cannot actively match a random wireless signal transmitter.

In order to create a wireless match, please check the manual of your wireless signal transmitter.

We advise you to use the W-DMX MicroBox F-1 G5 Transceiver ([50175](#)) by WIRELESS SOLUTION (Fig. 10).

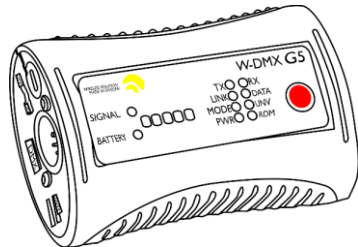

Fig. 10

Disconnect the Polar from the Wireless DMX Signal Transmitter

To turn W-DMX off, disable W-DMX by unlinking the fixture. See **4.5. Signal** on page 29 for more information. The Polar will now be disconnected.

Connecting to a Network

Art-Net Settings

- 01) Install any Art-Net-based software on your PC (Windows or Mac) or use a light controller which supports Art-Net.
- 02) Connect the power supply to the Polar.
- 03) Connect the device's RJ45 connector to the RJ45 connector of the lighting controller/network switch, using a CAT-5/CAT-6 cable.
- 04) Set the IP address of your computer/light controller to **2.x.x.x** or **10.x.x.x**, depending on the Art-Net settings. See **4.4. Network** on page 28 for more information.
- 05) Set the Subnet Mask of your computer/light controller to **255.0.0.0**.
- 06) Make sure that all fixtures in the network have a **unique IP address**.
- 07) If you want to connect more fixtures, follow the example below.

Example:

- 01) Make sure that each connected Polar has a **unique IP address**.
- 02) Make sure that the subnet mask on each device is set to **255.0.0.0**.
- 03) Set the universe of the first Polar to **1**.
- 04) Set the first Polar's DMX address to **001**.
- 05) Please note, that you can connect only 28 devices (28 x 18 channels = 504 channels needed). Due to the channel limit of 512, you cannot connect the 29th device to the same data line, as it would result in limited functionality of this device.
- 06) In order to solve this problem, set the universe of the 29th Polar to **2** and its DMX address to **001**.
- 07) When connecting multiple devices, you can repeat steps 5 and 6 up to 255 times, each time inserting ascending universe numbers (as there are 255 universes available).
- 08) Map all connected devices.
- 09) The connected Polars are now ready for use.
- 10) When creating large setups, it is recommended to use a 16-bit, high speed Ethernet switch to distribute the Art-Net data signal.

Art-Net is a protocol that uses TCP/IP to transfer large amount of DMX-512 data over an Ethernet network. Art-Net 4 can support up to 32768 universes. Art-Net™ Designed by and Copyright Artistic Licence Holdings Ltd.

sACN Settings

- 01) Connect the device's RJ45 connector to a network switch, using a CAT5/CAT6 cable.
- 02) Set the IP address of your computer/lighting controller. sACN networks have no restrictions on the IP address.
- 03) Set the Subnet mask on all devices.
- 04) Make sure that all fixtures in the network have a **unique IP address**.

sACN (streaming Architecture for Control Networks), also known as ANSI E1.31, is a protocol for sending DMX-512 data over IP networks developed by ESTA (Entertainment Services and Technology Association). It supports up to 63999 universes and uses multicasting.

How to Make a Data Cable

A standard ETHERNET cable can be used to replace the data cable required to transmit the data.

Please follow the instructions below in order to create an extra network cable.

Take a standard network cable (CAT-5/ 5E /6) and connect it to the RJ45 connector, as shown on Fig. 11. The wires should now be colored as follows:

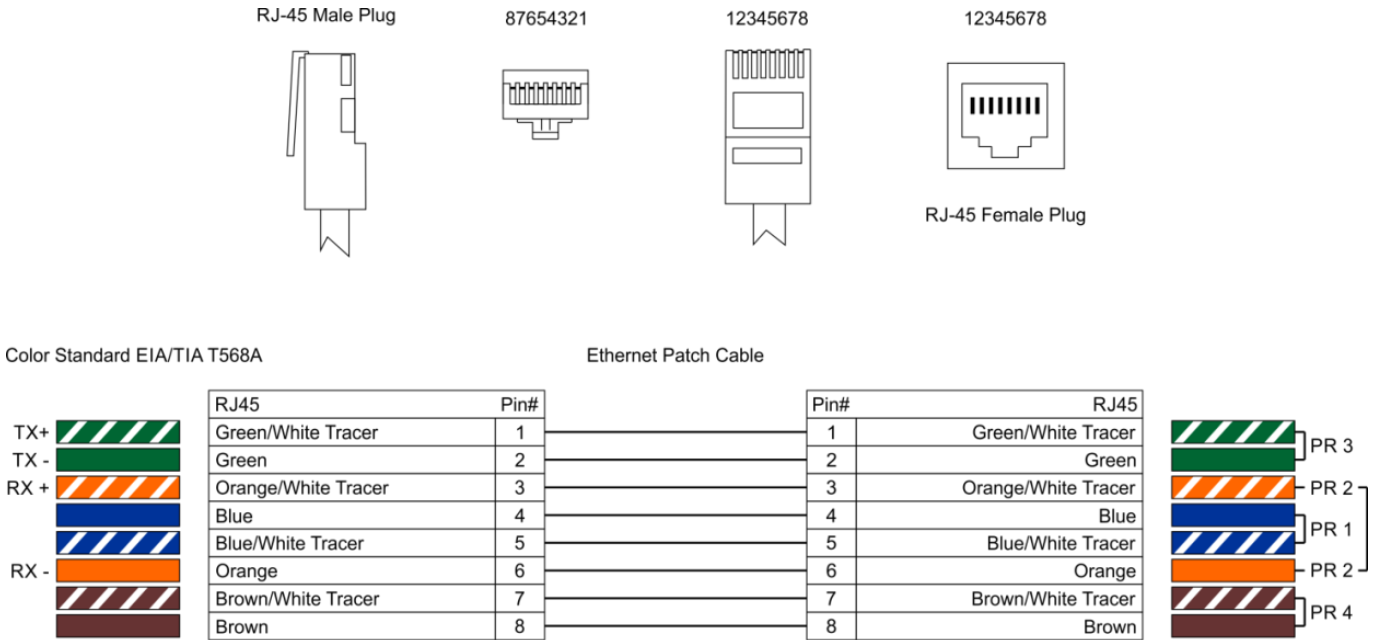

Fig. 11

Fixture Linking

You will need a serial data link to run light shows of one or more fixtures using a DMX-512 controller or to run synchronized shows of two or more fixtures set to a master/slave operating mode. The combined number of channels required by all the fixtures on a serial data link determines the number of fixtures the data link can support.

Important: Fixtures on a serial data link must be daisy-chained in a single line. To comply with the EIA-485 standard, no more than 30 devices should be connected on one data link. Connecting more than 30 fixtures on one serial data link without the use of a DMX optically isolated splitter may result in deterioration of the digital DMX signal.



Maximum recommended DMX data link distance: 100 meters
Maximum recommended number of fixtures on a DMX data link: 30 fixtures

Data Cabling

To link fixtures together, you must obtain data cables. You can purchase DAP Audio certified DMX cables directly from a dealer/distributor or construct your own cable. If you choose to create your own cable, please use data-grade cables that can carry a high quality signal and are less prone to electromagnetic interference.

DAP Audio DMX Data Cables

- DAP Audio DMX cable by Neutrik®. **Order code** FL71150 (1,5 m), FL713 (3 m), FL716 (6 m), FL7110 (10 m)
- DAP Audio DMX by Neutrik®. **Order code** FL7275 (0,75 m), FL72150 (1,5 m), FL723 (3 m), FL726 (6 m), FL7210 (10 m)
- DAP Audio 110 Ohm cable with digital signal transmission. **Order code** FL0975 (0,75 m), FL09150 (1,5 m), FL093 (3 m), FL096 (6 m), FL0910 (10 m), FL0915 (15 m), FL0920 (20 m)

Note: Connect the Polars with the dedicated special DMX cables for outdoor use.

FL83150	DMX cable 5p XLR IP65, Neutrik®, 1,5 m
FL833	DMX cable 5p XLR IP65, Neutrik®, 3 m
FL836	DMX cable 5p XLR IP65, Neutrik®, 6 m
FL8310	DMX cable 5p XLR IP65, Neutrik®, 10 m
FL8320	DMX cable 5p XLR IP65, Neutrik®, 20 m

The Polar 100 Beam IP65 Moving Head can be operated with controller or without controller in stand-alone mode.

Control Panel

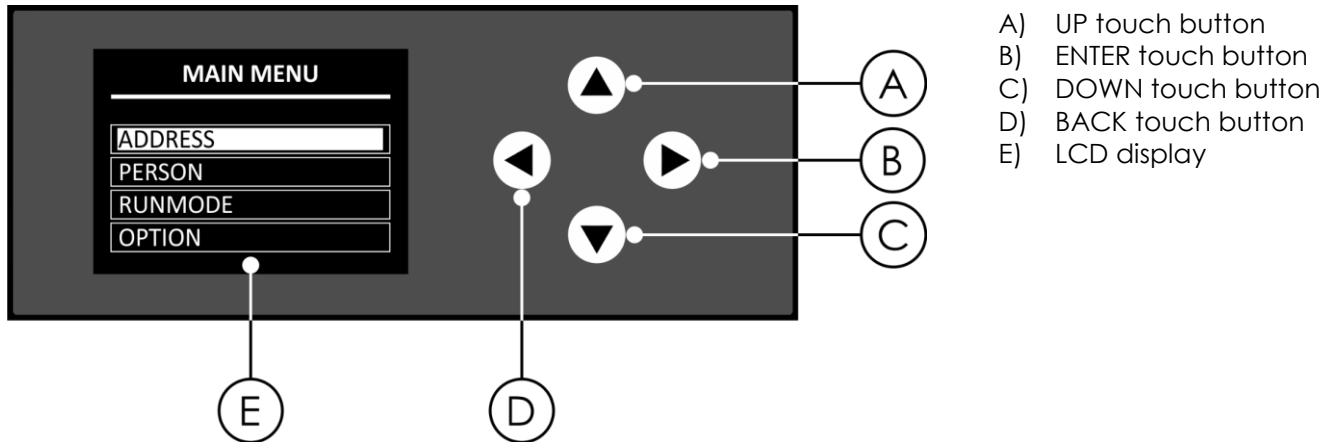

Fig. 12

DMX Addressing

The control panel on the front side of the base allows you to assign the fixture a DMX address, which is the first channel with which the Polar will respond to the controller.

Please note, when you use the controller, the unit has **18** channels.

When using multiple Polars, make sure you set the DMX addresses right.

Therefore, the DMX address of the first Polar should be **1 (001)**; the DMX address of the second Polar should be **1+18=19 (019)**; the DMX address of the third Polar should be **19+18=37 (037)**, etc.

Make sure that you do not have any overlapping channels in order to control each Polar correctly. If two or more Polars are addressed similarly, they will work similarly.

Controlling:

After having addressed all Polar fixtures, you may now start operating these via your lighting controller.

Note: After switching on, the Polar will automatically detect whether DMX-512 data is received or not. If there is no data received at the DMX input, the DMX address on the start screen will be blinking.

The problem may be:

- The DMX cable from the controller is not connected with the input of the Polar.
- The controller is switched off or defective, the cable or connector is defective, or the signal wires are swapped in the input connector.

Note: It is necessary to insert a termination plug (with 120 Ohm) in the last fixture in order to ensure proper transmission on the DMX data link.

Display Off after 60 seconds

When no button is pressed for 60 seconds, the display will turn off.

To light up the display, press and hold down the BACK button for 5 seconds.

Menu Overview

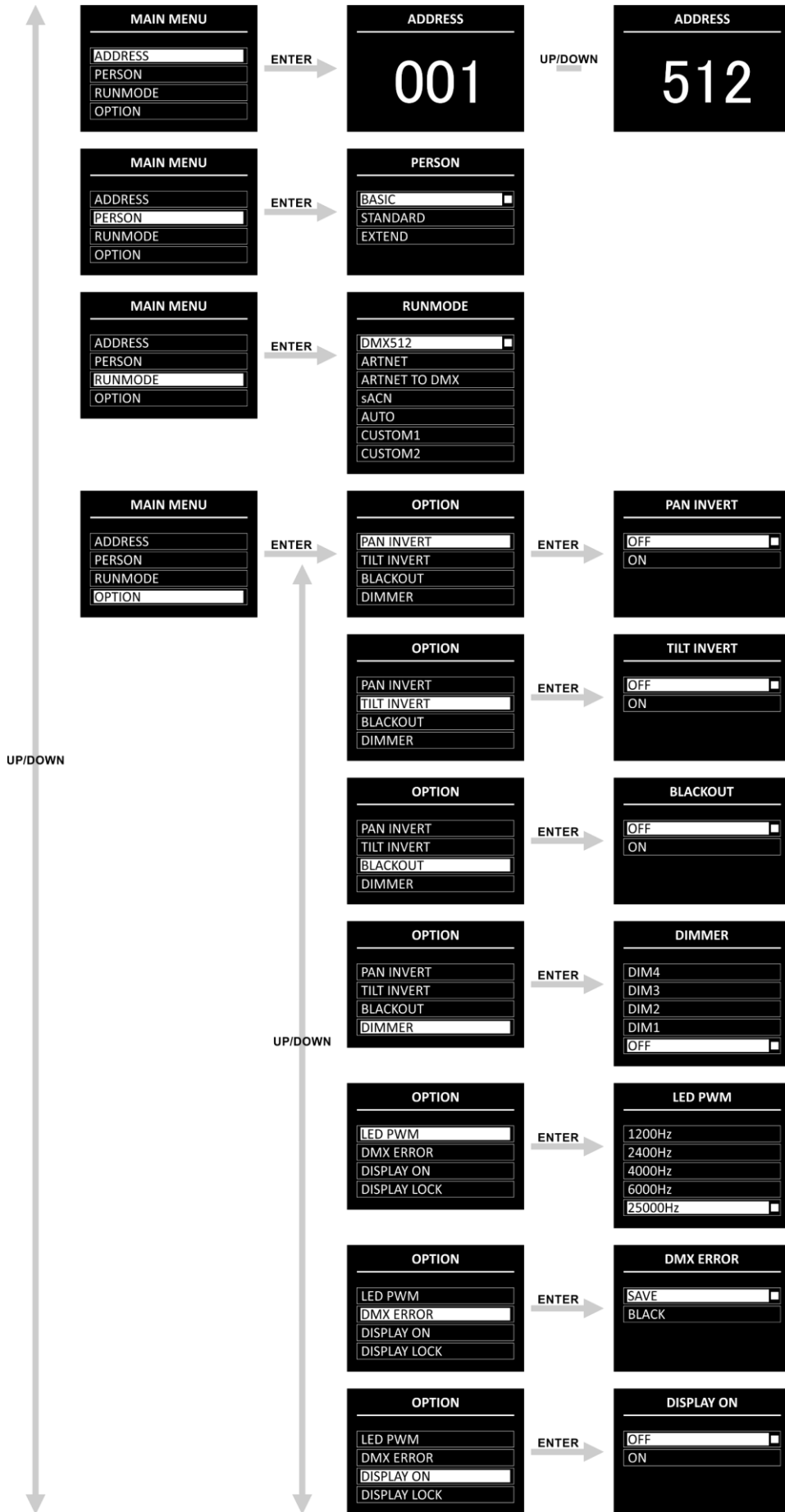

Polar 100 Beam IP65 Moving Head

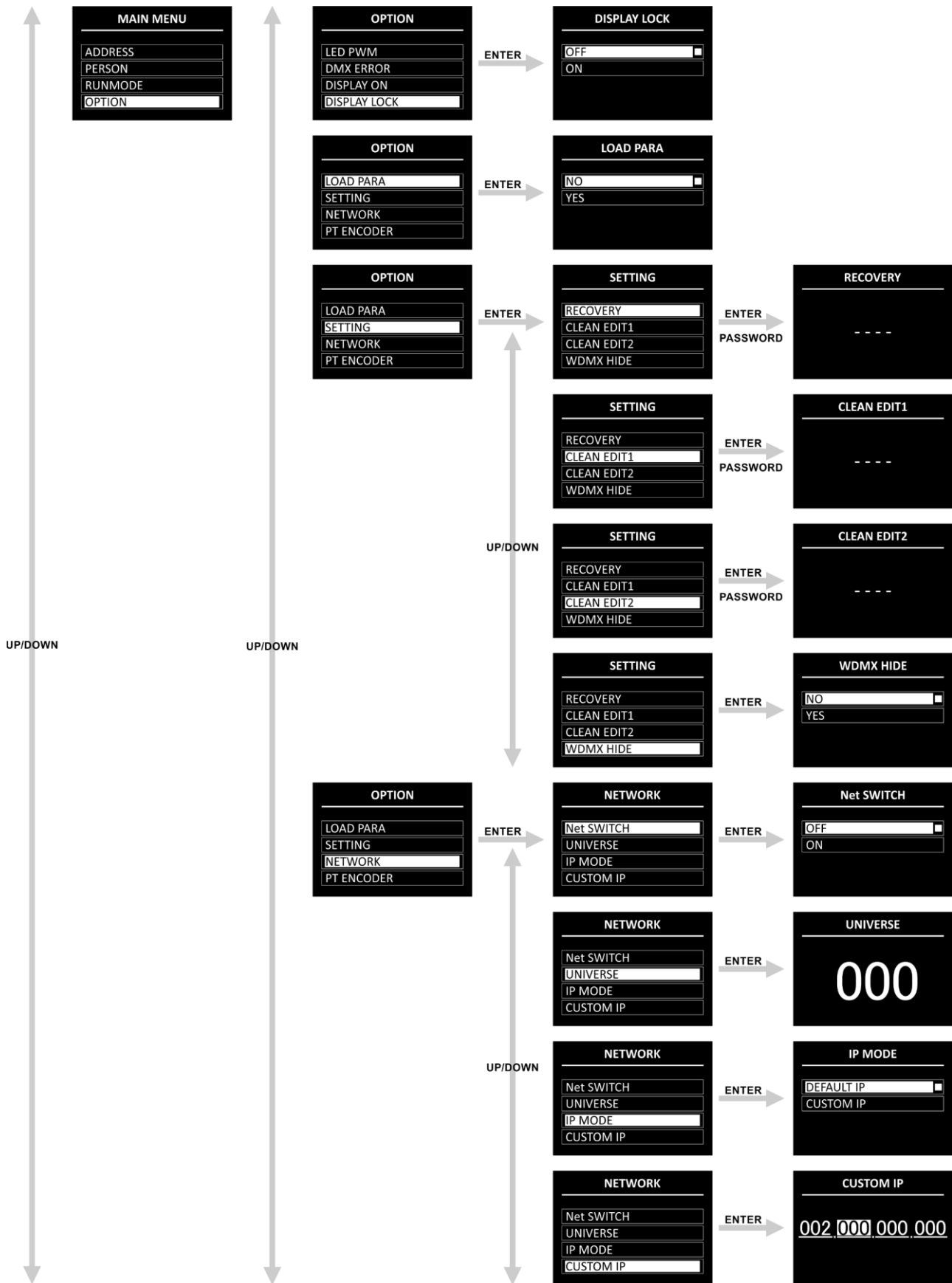

Polar 100 Beam IP65 Moving Head

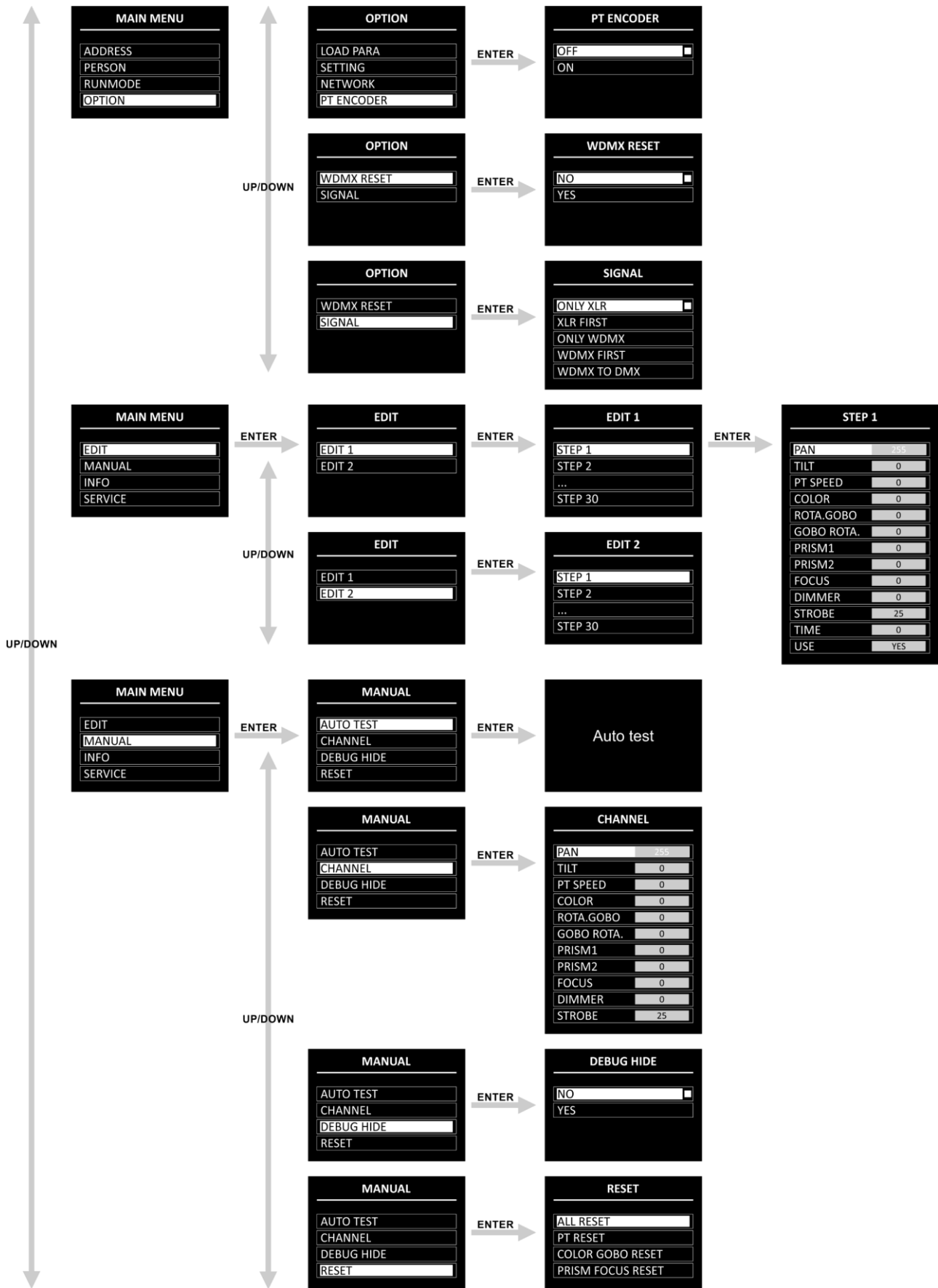

Polar 100 Beam IP65 Moving Head

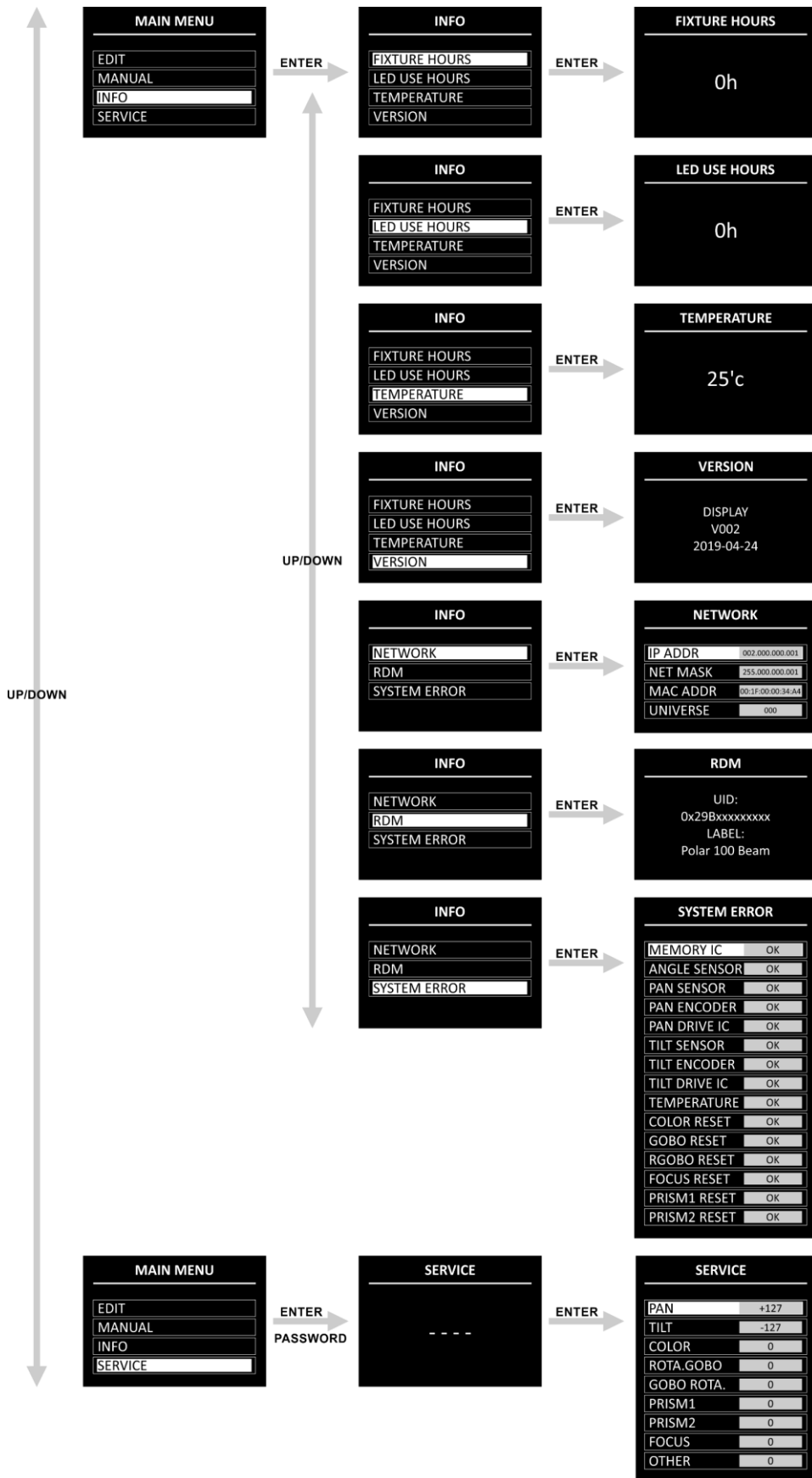

Start-up

After powering up, the fixture will perform a reset and the display will show the following splash screen:



When the resetting is completed, the device is ready to be operated. The display will show the start screen:



The start screen provides information about the active run mode of the device.

By default the display of the device is locked. To unlock the display and access the Main Menu, you will need to enter the **password**:

- 01) Press and hold down the **BACK** button for 5 seconds to light up the display.
- 02) Press the **UP/DOWN** buttons in the following order: **UP, DOWN, UP, DOWN**.
- 03) Press the **ENTER** button to confirm.

To change the settings and remove the display lock, see **4.2. Display Lock** on page 27.

If no button is pressed, after 60 seconds the display will turn off. Enter the password to unlock the display. If the display lock is turned off, press any button to turn the display on.

- Use the **UP/DOWN** buttons to navigate through the menus or to increase/decrease numeric values.
- Use the **ENTER** button to open the desired menu or to set the currently selected value.
- Use the **BACK** button to exit the current menu and/or to return to the Main Menu.

No Reset Start-up

It is not required to power up the Polar, in order to adjust the device's settings. It is possible to activate only the display. Press and hold down the **BACK** button for 5 seconds. As the display is equipped with a battery, the display will turn on and the Polar will remain off.

Main Menu Options

The Main Menu has the following options:

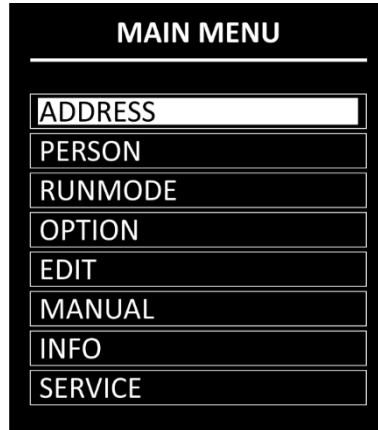

- 01) Press the **UP/DOWN** buttons to navigate through the Main Menu.
- 02) Press the **ENTER** button to open the submenus.

Note: Some of the submenus require a password. The default password is pressing the **UP/DOWN** buttons in the following order: **UP, DOWN, UP, DOWN**. Deactivating the display lock does not affect the submenu items which by default require a password.

1. DMX Address

In this menu you can set the device's DMX starting address.

- 01) Press the **UP/DOWN** buttons to set the desired DMX address. The adjustment range is between 001 and 512.
- 02) Press the **ENTER** button to save the changes.

2. Person (DMX Channel Modes)

In this menu you can set the DMX Channel Mode (Personality).

- 01) Press the **UP/DOWN** buttons to select the desired DMX channel mode. There are 3 options available:

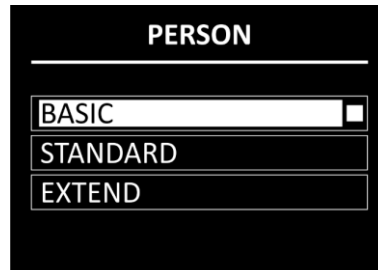

Basic: 12 channels
Standard: 15 channels
Extend: 18 channels

- 02) Press the **ENTER** button to confirm your choice. See pages 34–42 for the DMX Channel Modes.

3. Run Mode

In this menu you can set the control mode of the device.

- 01) Press the **UP/DOWN** buttons to select one of the following 7 options:
 - **DMX512:** The device will operate in DMX mode
 - **ARTNET:** The device will operate in Art-Net mode
 - **ARTNET TO DMX:** The device will receive the data via Ethernet and transmit it via DMX. When linking multiple devices, the first device can be connected to a computer with a CAT-5/CAT-6 cable and the rest of the devices can be linked using a DMX cable
 - **sACN:** The device will operate in sACN mode
 - **AUTO:** The device will run the built-in program
 - **CUSTOM1:** The device will run Custom Program 1. See **5. Edit** on page 29 for more information on how to edit the custom program

- CUSTOM2: The device will run Custom Program 2. See **5. Edit** on page 29 for more information on how to edit the custom program.

02) Press the **ENTER** button to confirm your choice.

4. Option

In this menu you can adjust the device's settings.

01) Press the **UP/DOWN** buttons to scroll through the following 14 options:

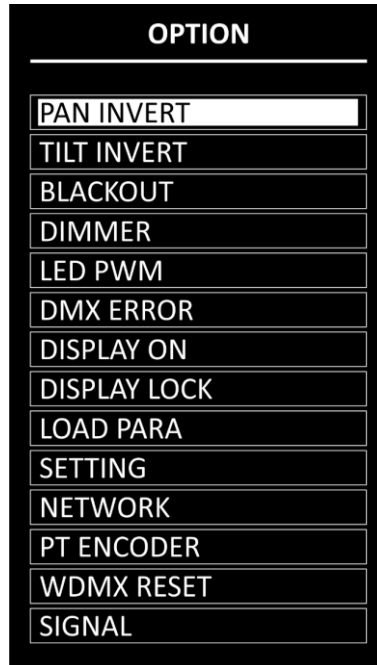

02) Press the **ENTER** button to confirm your choice.

The available submenus are:

- PAN INVERT: Pan direction will be inverted, depending on the position of the Polar (OFF/ON)
- TILT INVERT: Tilt direction will be inverted, depending on the position of the Polar (OFF/ON)
- BLACKOUT: Output blackout during pan/tilt movement (OFF/ON)
- DIMMER: See **4.1. Dimmer** for more information
- LED PWM: Adjustment of the LED's PWM (Pulse Width Modulation) frequency. The available options are 1200 Hz, 2400 Hz, 4000 Hz, 6000 Hz, and 25000 Hz
- DMX ERROR: Polar's behavior in case of a DMX error. There are 2 options: SAVE (the Polar will use the last properly received DMX signal which ensures uninterrupted performance) and BLACK (output blackout)
- DISPLAY ON: If you choose ON, the display will not turn off. If you choose OFF, the display will turn off after 60 seconds of inactivity
- DISPLAY LOCK: See **4.2. Display Lock** for more information
- LOAD PARA: Upload the parameters of Custom Program 1 and/or 2 from the master device to the slave device in master/slave mode (NO/YES)
- SETTING: See **4.3. Settings** for more information
- NETWORK: See **4.4. Network** for more information
- PT ENCODER: If the encoder is turned on (ON), the device will automatically correct the pan/tilt position, if it deviates from the last saved value (OFF/ON)
- WDMX RESET: Resets wireless connection and clears all receiver's messages (NO/YES)
- SIGNAL: See **4.5. Signal** for more information

4.1. Dimmer

In this submenu you can adjust the dimmer speed.

- 01) Select DIMMER and press the **ENTER** button to open the submenu.
- 02) Press the **UP/DOWN** buttons to choose one of the following options:
 - DIM 1, DIM 2, DIM 3, DIM 4: Non-linear dimmers, from fast to slow
 - OFF: Linear dimmer
- 03) Press the **ENTER** button to confirm your choice.

4.2. Display Lock

In this submenu you can activate the display lock.

Press the **UP/DOWN** buttons to toggle between ON and OFF.

- ON: Display lock is on. The display turns off after 60 seconds of inactivity. To access the Main Menu, you will need to enter the password. The default password is pressing the **UP/DOWN** buttons in the following order: **UP, DOWN, UP, DOWN**
- OFF: The Main Menu remains unlocked after the display turns off

Note: Deactivating the display lock does not affect the submenu items which by default require a password.

4.3. Settings

In this submenu you can reset some of the device's parameters.

- 01) Press the **UP/DOWN** buttons to scroll through the following 4 options:

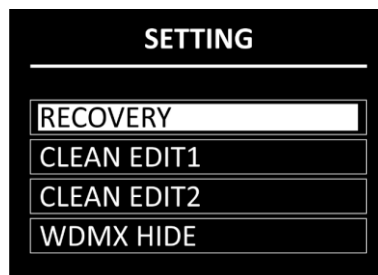

- 02) Press the **ENTER** button to confirm your choice.

4.3.1. Recovery

In this submenu you can restore the default factory settings. This submenu requires a **password**.

- 01) Press the **UP/DOWN** buttons in the following order: **UP, DOWN, UP, DOWN**.
- 02) Press the **ENTER** button to confirm the password and start the resetting.

4.3.2. Clean Edit 1

In this submenu you can clear all settings of Custom Program 1. This submenu requires a **password**.

- 01) Press the **UP/DOWN** buttons in the following order: **UP, DOWN, UP, DOWN**.
- 02) Press the **ENTER** button to confirm the password. All changes made in EDIT 1 (see pages 29–30) will be reset.

4.3.3. Clean Edit 2

In this submenu you can clear all settings of Custom Program 2. This submenu requires a **password**.

- 01) Press the **UP/DOWN** buttons in the following order: **UP, DOWN, UP, DOWN**.
- 02) Press the **ENTER** button to confirm the password. All changes made in EDIT 2 (see pages 29–30) will be reset.

4.3.4. WDMX Hide

In this submenu you can hide the wireless mode settings.

- 01) Press the **UP/DOWN** buttons to toggle between:
 - NO: The wireless mode settings (WMDX RESET and SIGNAL) will be visible in the menu
 - YES: The wireless mode settings (WMDX RESET and SIGNAL) will not be visible in the menu
- 02) Press the **ENTER** button to confirm your choice.

4.4. Network

In this submenu you can adjust the network settings.

01) Press the **UP/DOWN** buttons to scroll through the following 4 options:

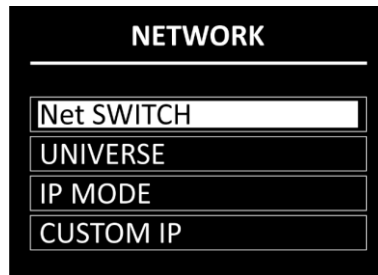

02) Press the **ENTER** button to confirm your choice.

The available options are:

- **Net SWITCH:** Set the starting number of the IP address of the device. Select OFF for an IP address starting with 2.x.x.x and ON for an IP address starting with 10.x.x.x
- **UNIVERSE:** Set the universe of the device (0–255)
- **IP MODE:** See **4.4.1. IP Mode** for more information
- **CUSTOM IP:** See **4.4.2. Custom IP** for more information

4.4.1. IP Mode

In this menu you can choose the IP mode.

01) Press the **UP/DOWN** buttons to toggle between the following 2 options:

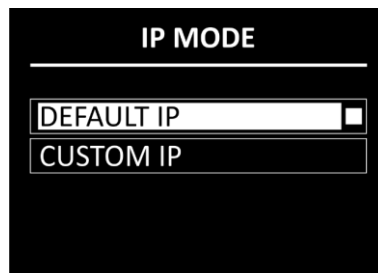

- **DEFAULT IP:** The IP address of the device will be generated automatically by the network server
- **CUSTOM IP:** The IP address of the device can be configured manually (see **4.4.2. Custom IP**)

02) Press the **ENTER** button to confirm your choice.

4.4.2. Custom IP

In this menu you can configure manually the IP address of the device.

01) Press the **ENTER/BACK** buttons to move the cursor respectively to the right/left on the display. The selected number will be highlighted.

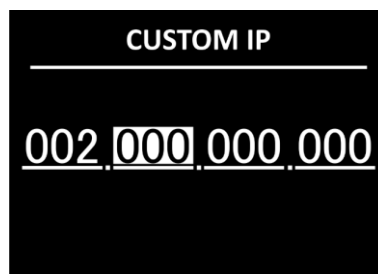

02) Press the **UP/DOWN** buttons to change the number. The selection range is between 0 and 255.

03) Press the **ENTER** button to confirm and to move to the next number.

04) Repeat steps 1–3 for each of the 3 editable sections of the IP address. To change the starting number of the IP address, see **4.4. Network** on page 28.

4.5. Signal

In this submenu you can enable W-DMX and set the signal preferences.

01) Press the **UP/DOWN** buttons to scroll through the following 5 options:

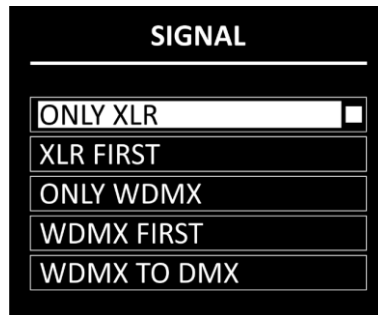

02) Press the **ENTER** button to confirm your choice.

The available options are:

- ONLY XLR
- XLR FIRST
- ONLY WDMX
- WDMX FIRST
- WDMX TO DMX:

When linking multiple Polars, you can set a wireless connection from your computer to the first device and link the rest of the devices using a DMX cable

5. Edit

In this menu you can edit the custom programs thus creating your own custom show.

01) Press the **UP/DOWN** buttons to choose one of the two custom programs you want to edit (EDIT 1 or EDIT 2).

02) Press the **ENTER** button to confirm the selection. Each custom program has 30 steps, which can be edited:

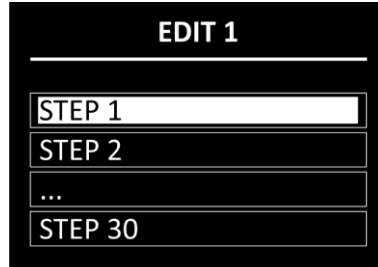

03) Press the **UP/DOWN** buttons to select the desired step.

04) Press the **ENTER** button to open the settings submenu of the respective step.

05) Press the **UP/DOWN** buttons to scroll through the 13 available options:

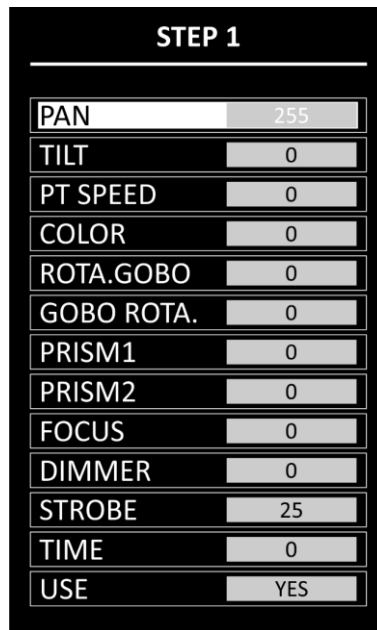

- 06) Press the **ENTER** button to confirm the selection.
- 07) Press the **UP/DOWN** buttons to increase/decrease the values.
- PAN: Pan position adjustment (0–255)
 - TILT: Tilt position adjustment (0–255)
 - PT SPEED: Pan/tilt speed (0–255)
 - COLOR: Color temperature (0–255)
 - ROTA.GOBO: Gobo position (0–255)
 - GOBO ROTA.: Gobo indexing (0–255)
 - PRISM1: Prism 1 adjustment (0–255)
 - PRISM2: Prism 2 adjustment (0–255)
 - FOCUS: Focus adjustment (0–255)
 - DIMMER: From OFF to full ON (0–255)
 - STROBE: From OFF to high frequency (0–25)
 - TIME: Set the duration of the step (0–255, from 0,1 to approximately 25 seconds)
 - USE: Include the step in the custom program (YES/NO). If you choose NO, the step will be excluded during the custom program play
- 08) Press the **ENTER** button to set the value.
- 09) Repeat steps 3–7 above for the remaining steps of the custom program.

Note: For each custom program you can create 30 steps, which makes it possible to create 60 customized scenes in total.

6. Manual

In this menu you can manually adjust and reset the device's parameters.

- 01) Press the **UP/DOWN** buttons to scroll through the following 4 options.

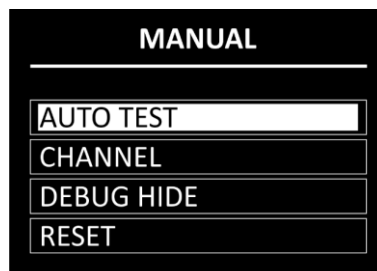

- 02) Press the **ENTER** button to confirm your choice.
- The available options are:
- AUTO TEST: Auto test of the device's parameters
 - CHANNEL: See **6.1. Channel** for more information
 - DEBUG HIDE: This option is not relevant to the use and operation of the device
 - RESET: See **6.2. Reset** for more information

6.1. Channel

In this menu you can manually adjust the device's parameters.

01) Press the **UP/DOWN** buttons to scroll through the following 11 options.

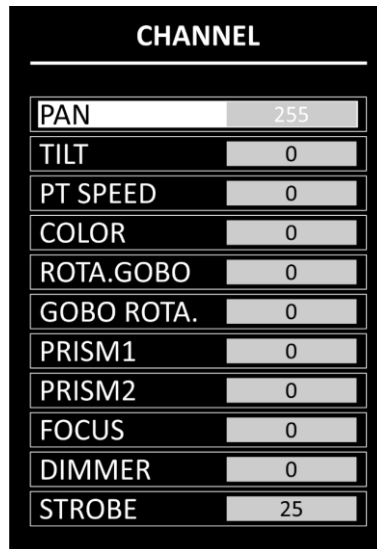

02) Press the **ENTER** button to select the parameter.

03) Press the **UP/DOWN** buttons to increase/decrease the values.

- PAN: Pan position adjustment (0–255)
- TILT: Tilt position adjustment (0–255)
- PT SPEED: Pan/tilt speed (0–255)
- COLOR: Color temperature (0–255)
- ROTA.GOBO: Gobo position (0–255)
- GOBO ROTA.: Gobo indexing (0–255)
- PRISM1: Prism 1 adjustment (0–255)
- PRISM2: Prism 2 adjustment (0–255)
- FOCUS: Focus adjustment (0–255)
- DIMMER: From OFF to full ON (0–255)
- STROBE: From OFF to high frequency (0–25)

04) Press the **ENTER** button to set the value.

6.2. Reset

In this menu you can manually reset some of the device's parameters.

01) Press the **UP/DOWN** buttons to scroll through the following 4 options.

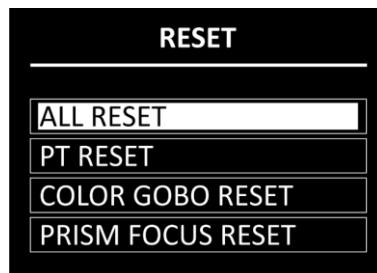

02) Press the **ENTER** button to confirm your choice. The reset of the parameters will be carried out.

- ALL RESET: Resetting of all parameters
- PT RESET: Resetting of the Pan/Tilt to home position
- COLOR GOBO RESET: Resetting of the color and gobo wheels to home position
- PRISM FOCUS RESET: Resetting of the prism and the focus to home position

7. Info

In this menu you can view the device's parameters.

01) Press the **UP/DOWN** buttons to scroll through the following 7 options:

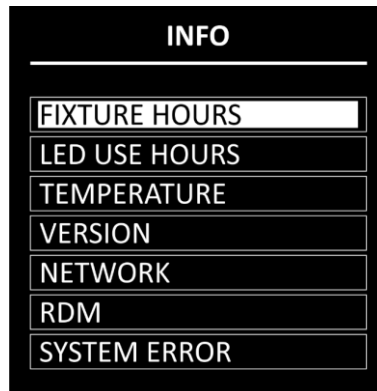

02) Press the **ENTER** button to confirm your choice and view the parameter.

The following options are available:

- **FIXTURE HOURS:** Shows the total hours of operation of the fixture
- **LED USE HOURS:** Shows the total hours of use of the LEDs
- **TEMPERATURE:** Shows the temperature of the LEDs
- **VERSION:** Provides information about the firmware version of the following parameters: DISPLAY, PAN, TILT, GOBO and FOCUS. Press the **UP/DOWN** buttons to scroll through the 5 screens
- **NETWORK:** Shows the network settings of the device (IP ADDRESS, SUBNET MASK, MAC ADDRESS and UNIVERSE)
- **RDM:** Shows the UID number and name (LABEL) of the device
- **SYSTEM ERROR:** See **7.1. System Error** for more information

7.1. System Error

In this menu you can view whether there are any system errors.

Press the **UP/DOWN** buttons to scroll through the following 15 options:

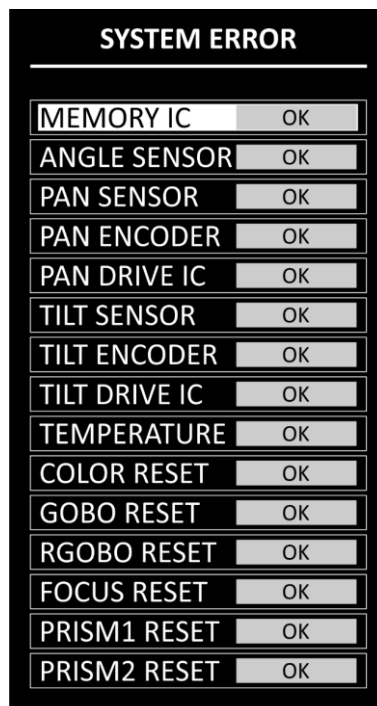

The displayed parameters are:

- MEMORY IC
- ANGLE SENSOR
- PAN SENSOR
- PAN ENCODER
- PAN DRIVE IC
- TILT SENSOR
- TILT ENCODER
- TILT DRIVE IC
- TEMPERATURE
- COLOR RESET
- GOBO RESET
- RGOBO RESET
- FOCUS RESET
- PRISM1 RESET
- PRISM2 RESET

If there are no errors, the display will show OK next to the parameter. If there are errors, the display will show ERROR.

8. Service

In this menu you can make fine adjustments of the home position of all moving parts. This submenu requires a **password**.

- 01) Press the **UP/DOWN** buttons in the following order: **UP, DOWN, UP, DOWN**.
- 02) Press the **ENTER** button to confirm the password and enter the submenu.
- 03) Press the **UP/DOWN** buttons to scroll through the following 9 options:

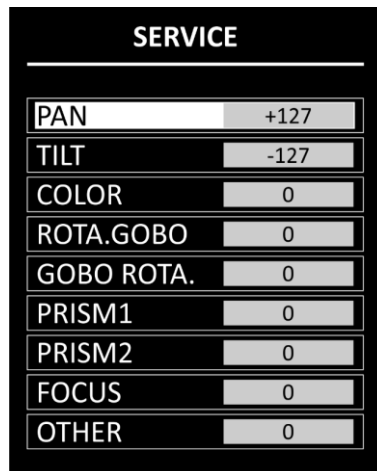

SERVICE	
PAN	+127
TILT	-127
COLOR	0
ROTA.GOBO	0
GOBO ROTA.	0
PRISM1	0
PRISM2	0
FOCUS	0
OTHER	0

- 04) Press the **ENTER** button to confirm your choice.
- 05) Press the **UP/DOWN** buttons to increase/decrease the value. The adjustment range is between -127 and +127.
- 06) Press the **ENTER** button to set the value.
The available options are:
 - PAN
 - TILT
 - COLOR (color wheel)
 - ROTA.GOBO (gobo wheel)
 - GOBO ROTA. (gobo rotation)
 - PRISM1
 - PRISM2
 - FOCUS
 - OTHER (this parameter is not relevant to the use and operation of the device)

DMX Channels

12 Channels (Basic)

Channel 1 – Horizontal movement (Pan)

Push the slider up, in order to move the head horizontally (PAN).
Gradual horizontal rotation of the head from 0° to 540° (0–255).
The head can be stopped at any position.

Channel 2 – Vertical movement (Tilt)

Push the slider up, in order to move the head vertically (TILT).
Gradual vertical rotation of the head from 0° to 270° (0–255).
The head can be stopped at any position.

Channel 3 – Pan/Tilt Speed

0–255 From fast to slow

Channel 4 – Color Wheel ⚠ CH10 must be open ⚠

0–7	White
8–12	Color 1: Red
13–18	Color 2: Yellow
19–24	Color 3: Green
25–30	Color 4: Orange
31–36	Color 5: Purple
37–42	Color 6: Blue
43–48	Color 7: Cyan
49–54	Color 8: CTO
55–60	Color 9: UV
61–66	White
67–73	Gradual color split: White/Red
74–79	Red
80–85	Gradual color split: Red/Yellow
86–92	Yellow
93–98	Gradual color split: Yellow/Green
99–105	Green
106–112	Gradual color split: Green/Orange
113–118	Orange
119–125	Gradual color split: Orange/Purple
126–131	Purple
132–136	Gradual color split: Purple/Blue
137–144	Blue
145–149	Gradual color split: Blue/Cyan
150–155	Cyan
156–162	Gradual color split: Cyan/CTO
163–169	CTO
170–176	Gradual color split: CTO/UV
177–182	UV
183–188	Gradual color split: UV/White
189–191	White
192–222	Continuous clockwise rotation (positive rainbow effect), from fast to slow
223–224	Stop
225–255	Continuous counterclockwise rotation (negative rainbow effect), from slow to fast

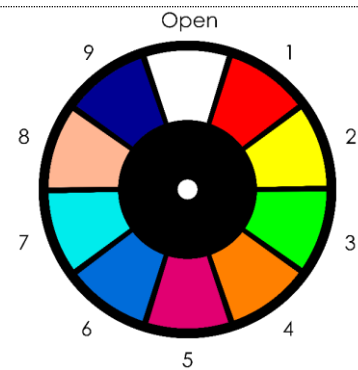

Channel 5 – Rotating Gobo Wheel ⚠ CH10 must be open ⚠

0–10	Open
11–16	Gobo 1
17–22	Gobo 2
23–28	Gobo 3
29–34	Gobo 4
35–40	Gobo 5
41–46	Gobo 6
47–52	Gobo 7
53–58	Gobo 8
59–66	Gobo 1 shake, from slow to fast
67–74	Gobo 2 shake, from slow to fast
75–82	Gobo 3 shake, from slow to fast
83–90	Gobo 4 shake, from slow to fast
91–98	Gobo 5 shake, from slow to fast
99–106	Gobo 6 shake, from slow to fast
107–114	Gobo 7 shake, from slow to fast
115–122	Gobo 8 shake, from slow to fast
123–127	Open
128–190	Clockwise gobo flow, from fast to slow
191–192	Stop
193–255	Counterclockwise gobo flow, from slow to fast

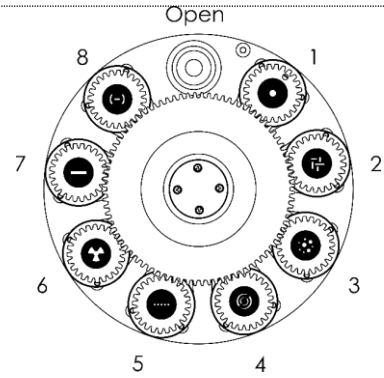

Channel 6 – Gobo Rotation

0–120	Gobo indexing, 0–360°
121–125	Stop
126–165	Gobo bounce effect, from slow to fast
166–170	Stop
171–210	Clockwise gobo rotation, from fast to slow
211–215	Stop
216–255	Counterclockwise gobo rotation, from slow to fast

Channel 7 – Prism 1 (24-facet circular prism)

0–10	Open
11–145	Prism 1 indexing
146–150	Stop
151–200	Clockwise rotation, from fast to slow
201–205	Stop
206–255	Counterclockwise rotation, from slow to fast

Channel 8 – Prism 2 (5-facet linear prism)

0–10	Open
11–145	Prism 2 indexing
146–150	Stop
151–200	Clockwise rotation, from fast to slow
201–205	Stop
206–255	Counterclockwise rotation, from slow to fast

Channel 9 – Focus

0–255	Gradual focus adjustment, 0–100%
-------	----------------------------------

Channel 10 – Master Dimmer

0–255	Gradual adjustment of the brightness, from low to high intensity (0–100 %)
-------	--

Channel 11 – Strobe ⚠ CH10 must be open ⚠

0–9	No function
10–99	Strobe flash rate, from low to high frequency (0–25 Hz)
100–109	No function
110–179	Pulse strobe, from low to high rate
180–189	No function
190–255	Random strobe, from low to high rate

Channel 12 – Control

0–10	No function
11–20	Blackout during Pan/Tilt movement ON
21–30	Blackout during Pan/Tilt movement OFF
31–40	Pan invert
41–50	Tilt invert
51–60	Pan/Tilt invert OFF
61–100	No function
101–110	DIM4
111–120	DIM3
121–130	DIM2
131–140	DIM1
141–150	DIM OFF
151–160	PWM 1200 Hz
161–170	PWM 2400 Hz
171–180	PWM 4000 Hz
181–190	PWM 6000 Hz
191–200	PWM 25000 Hz
201–210	All reset
211–220	XY reset
221–230	Color/Gobo wheel reset
231–255	Prism focus reset

15 Channels (Standard)

Channel 1 – Horizontal movement (Pan)

Push the slider up, in order to move the head horizontally (PAN).
Gradual horizontal rotation of the head from 0° to 540° (0–255).
The head can be stopped at any position.

Channel 2 – Pan Fine, 16 bit

Channel 3 – Vertical movement (Tilt)

Push the slider up, in order to move the head vertically (TILT).
Gradual vertical rotation of the head from 0° to 270° (0–255).
The head can be stopped at any position.

Channel 4 – Tilt fine, 16 bit

Channel 5 – Pan/Tilt Speed

0–255 From fast to slow

Channel 6 – Color Wheel ⚠ CH12 must be open ⚠

0–7	White
8–12	Color 1: Red
13–18	Color 2: Yellow
19–24	Color 3: Green
25–30	Color 4: Orange
31–36	Color 5: Purple
37–42	Color 6: Blue
43–48	Color 7: Cyan
49–54	Color 8: CTO
55–60	Color 9: UV
61–66	White
67–73	Gradual color split: White/Red
74–79	Red
80–85	Gradual color split: Red/Yellow
86–92	Yellow
93–98	Gradual color split: Yellow/Green
99–105	Green
106–112	Gradual color split: Green/Orange
113–118	Orange
119–125	Gradual color split: Orange/Purple
126–131	Purple
132–136	Gradual color split: Purple/Blue
137–144	Blue
145–149	Gradual color split: Blue/Cyan
150–155	Cyan
156–162	Gradual color split: Cyan/CTO
163–169	CTO
170–176	Gradual color split: CTO/UV
177–182	UV
183–188	Gradual color split: UV/White
189–191	White
192–222	Continuous clockwise rotation (positive rainbow effect), from fast to slow
223–224	Stop
225–255	Continuous counterclockwise rotation (negative rainbow effect), from slow to fast

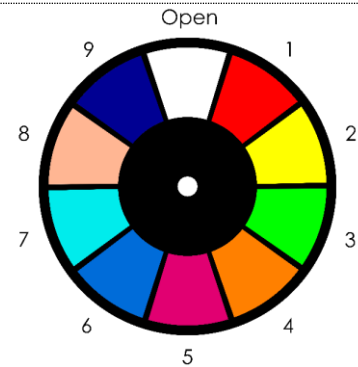

Channel 7 – Rotating Gobo Wheel ⚠ CH12 must be open ⚠

0–10	Open
11–16	Gobo 1
17–22	Gobo 2
23–28	Gobo 3
29–34	Gobo 4
35–40	Gobo 5
41–46	Gobo 6
47–52	Gobo 7
53–58	Gobo 8
59–66	Gobo 1 shake, from slow to fast
67–74	Gobo 2 shake, from slow to fast
75–82	Gobo 3 shake, from slow to fast
83–90	Gobo 4 shake, from slow to fast
91–98	Gobo 5 shake, from slow to fast
99–106	Gobo 6 shake, from slow to fast
107–114	Gobo 7 shake, from slow to fast
115–122	Gobo 8 shake, from slow to fast
123–127	Open
128–190	Clockwise gobo flow, from fast to slow
191–192	Stop
193–255	Counterclockwise gobo flow, from slow to fast

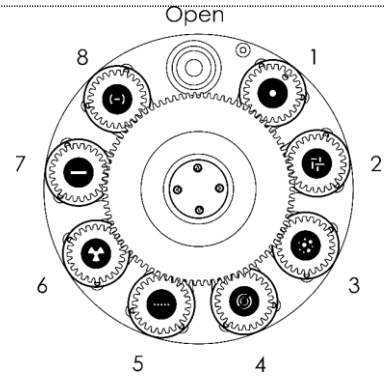

Channel 8 – Gobo Rotation

0–120	Gobo indexing, 0–360°
121–125	Stop
126–165	Gobo bounce effect, from slow to fast
166–170	Stop
171–210	Clockwise gobo rotation, from fast to slow
211–215	Stop
216–255	Counterclockwise gobo rotation, from slow to fast

Channel 9 – Prism 1 (24-facet circular prism)

0–10	Open
11–145	Prism 1 indexing
146–150	Stop
151–200	Clockwise rotation, from fast to slow
201–205	Stop
206–255	Counterclockwise rotation, from slow to fast

Channel 10 – Prism 2 (5-facet linear prism)

0–10	Open
11–145	Prism 2 indexing
146–150	Stop
151–200	Clockwise rotation, from fast to slow
201–205	Stop
206–255	Counterclockwise rotation, from slow to fast

Channel 11 – Focus

0–255	Gradual focus adjustment, 0–100%
-------	----------------------------------

Channel 12 – Master Dimmer

0–255	Gradual adjustment of the brightness, from low to high intensity (0–100 %)
-------	--

Channel 13 – Dimmer Fine ⚠ CH12 must be open ⚠

0–255 Fine adjustment of the brightness, from low to high intensity (0–100 %)

Channel 14 – Strobe ⚠ CH12 must be open ⚠

0–9 No function
10–99 Strobe flash rate, from low to high frequency (0–25 Hz)
100–109 No function
110–179 Pulse strobe, from low to high rate
180–189 No function
190–255 Random strobe, from low to high rate

Channel 15 – Control

0–10 No function
11–20 Blackout during Pan/Tilt movement ON
21–30 Blackout during Pan/Tilt movement OFF
31–40 Pan invert
41–50 Tilt invert
51–60 Pan/Tilt invert OFF
61–100 No function
101–110 DIM4
111–120 DIM3
121–130 DIM2
131–140 DIM1
141–150 DIM OFF
151–160 PWM 1200 Hz
161–170 PWM 2400 Hz
171–180 PWM 4000 Hz
181–190 PWM 6000 Hz
191–200 PWM 25000 Hz
201–210 All reset
211–220 XY reset
221–230 Color/Gobo wheel reset
231–255 Prism focus reset

18 Channels (Extended)

Channel 1 – Horizontal movement (Pan)

Push the slider up, in order to move the head horizontally (PAN).
Gradual horizontal rotation of the head from 0° to 540° (0–255).
The head can be stopped at any position.

Channel 2 – Pan Fine, 16 bit

Channel 3 – Vertical movement (Tilt)

Push the slider up, in order to move the head vertically (TILT).
Gradual vertical rotation of the head from 0° to 270° (0–255).
The head can be stopped at any position.

Channel 4 – Tilt fine, 16 bit

Channel 5 – Pan/Tilt Speed

0–255 From fast to slow

Channel 6 – Color Wheel ⚠ CH15 must be open ⚠

0–7	White
8–12	Color 1: Red
13–18	Color 2: Yellow
19–24	Color 3: Green
25–30	Color 4: Orange
31–36	Color 5: Purple
37–42	Color 6: Blue
43–48	Color 7: Cyan
49–54	Color 8: CTO
55–60	Color 9: UV
61–66	White
67–73	Gradual color split: White/Red
74–79	Red
80–85	Gradual color split: Red/Yellow
86–92	Yellow
93–98	Gradual color split: Yellow/Green
99–105	Green
106–112	Gradual color split: Green/Orange
113–118	Orange
119–125	Gradual color split: Orange/Purple
126–131	Purple
132–136	Gradual color split: Purple/Blue
137–144	Blue
145–149	Gradual color split: Blue/Cyan
150–155	Cyan
156–162	Gradual color split: Cyan/CTO
163–169	CTO
170–176	Gradual color split: CTO/UV
177–182	UV
183–188	Gradual color split: UV/White
189–191	White
192–222	Continuous clockwise rotation (positive rainbow effect), from fast to slow
223–224	Stop
225–255	Continuous counterclockwise rotation (negative rainbow effect), from slow to fast

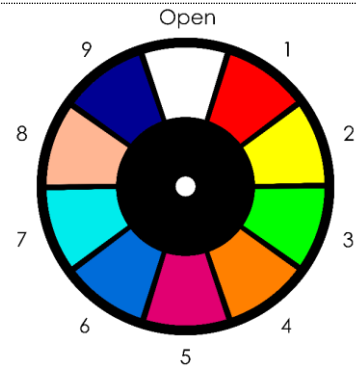

Channel 7 – Color Wheel Fine ⚠ CH15 must be open ⚠

0–255 Color wheel fine

Channel 8 – Rotating Gobo Wheel ⚠ CH15 must be open ⚠

0–10	Open
11–16	Gobo 1
17–22	Gobo 2
23–28	Gobo 3
29–34	Gobo 4
35–40	Gobo 5
41–46	Gobo 6
47–52	Gobo 7
53–58	Gobo 8
59–66	Gobo 1 shake, from slow to fast
67–74	Gobo 2 shake, from slow to fast
75–82	Gobo 3 shake, from slow to fast
83–90	Gobo 4 shake, from slow to fast
91–98	Gobo 5 shake, from slow to fast
99–106	Gobo 6 shake, from slow to fast
107–114	Gobo 7 shake, from slow to fast
115–122	Gobo 8 shake, from slow to fast
123–127	Open
128–190	Clockwise gobo flow, from fast to slow
191–192	Stop
193–255	Counterclockwise gobo flow, from slow to fast

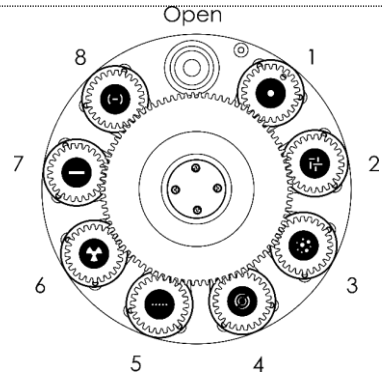

Channel 9 – Gobo Rotation

0–120	Gobo indexing, 0–360°
121–125	Stop
126–165	Gobo bounce effect, from slow to fast
166–170	Stop
171–210	Clockwise gobo rotation, from fast to slow
211–215	Stop
216–255	Counterclockwise gobo rotation, from slow to fast

Channel 10 – Rotation Gobo Wheel Fine

0–255	Gobo indexing, Fine
-------	---------------------

Channel 11 – Prism 1 (24-facet circular prism)

0–10	Open
11–145	Prism 1 indexing
146–150	Stop
151–200	Clockwise rotation, from fast to slow
201–205	Stop
206–255	Counterclockwise rotation, from slow to fast

Channel 12 – Prism 2 (5-facet linear prism)

0–10	Open
11–145	Prism 2 indexing
146–150	Stop
151–200	Clockwise rotation, from fast to slow
201–205	Stop
206–255	Counterclockwise rotation, from slow to fast

Channel 13 – Focus

0–255	Gradual focus adjustment, 0–100%
-------	----------------------------------

Channel 14 – Focus Fine

0–255	Fine focus adjustment
-------	-----------------------

Channel 15 – Master Dimmer

0–255 Gradual adjustment of the brightness, from low to high intensity (0–100 %)

Channel 16 – Dimmer Fine ⚠ CH15 must be open ⚠

0–255 Fine adjustment of the brightness, from low to high intensity (0–100 %)

Channel 17 – Strobe ⚠ CH15 must be open ⚠

0–9 No function

10–99 Strobe flash rate, from low to high frequency (0–25 Hz)

100–109 No function

110–179 Pulse strobe, from low to high rate

180–189 No function

190–255 Random strobe, from low to high rate

Channel 18 – Control

0–10 No function

11–20 Blackout during Pan/Tilt movement ON

21–30 Blackout during Pan/Tilt movement OFF

31–40 Pan invert

41–50 Tilt invert

51–60 Pan/Tilt invert OFF

61–100 No function

101–110 DIM4

111–120 DIM3

121–130 DIM2

131–140 DIM1

141–150 DIM OFF

151–160 PWM 1200 Hz

161–170 PWM 2400 Hz

171–180 PWM 4000 Hz

181–190 PWM 6000 Hz

191–200 PWM 25000 Hz

201–210 All reset

211–220 XY reset

221–230 Color/Gobo wheel reset

231–255 Prism focus reset

Maintenance

The operator has to make sure that safety-related and machine-technical installations are to be inspected by an expert after every year in the course of an acceptance test.

The operator has to make sure that safety-related and machine-technical installations are to be inspected by a skilled person once a year.

The following points have to be considered during the inspection:

- 01) All screws used for installing the device or parts of the device have to be tightly connected and must not be corroded.
- 02) There may not be any deformations on housings, fixations and installation spots.
- 03) Mechanically moving parts like axles, eyes and others may not show any traces of wearing.
- 04) The electric power supply cables must not show any damages or material fatigue.

The Polar 100 Beam IP 65 Moving Head requires almost no maintenance. However, you should keep the unit clean.

Otherwise the fixture's light output will be significantly reduced. Disconnect the mains power supply, and then wipe the cover with a damp cloth. Do not immerse in liquid. Wipe lens clean with glass cleaner and a soft cloth. Do not use alcohol or solvents.

The front lens will require weekly cleaning, as smoke-fluid tends to build up residues, reducing the light output very quickly.

Keep connections clean. Disconnect electric power, and then wipe the DMX and audio connections with a damp cloth. Make sure connections are thoroughly dry before linking equipment or supplying electric power.

Replacing the Fuse

Power surges, short-circuit or inappropriate electrical power supply may cause a fuse to burn out. If the fuse burns out, the product will not function whatsoever. If this happens, follow the directions below.

- 01) Unplug the unit from electric power source.
- 02) Insert a flat-headed screwdriver into the slot in the fuse cover. Turn the screwdriver to the left, at the same time gently push a bit. The fuse will come out.
- 03) Remove the used fuse. If brown or unclear, it is burned out.
- 04) Insert the replacement fuse into the holder where the old fuse was. Reinsert the fuse holder. Be sure to use a fuse of the same type and specification. See the product specification label for details.

Gobo Wheel and Color Wheel

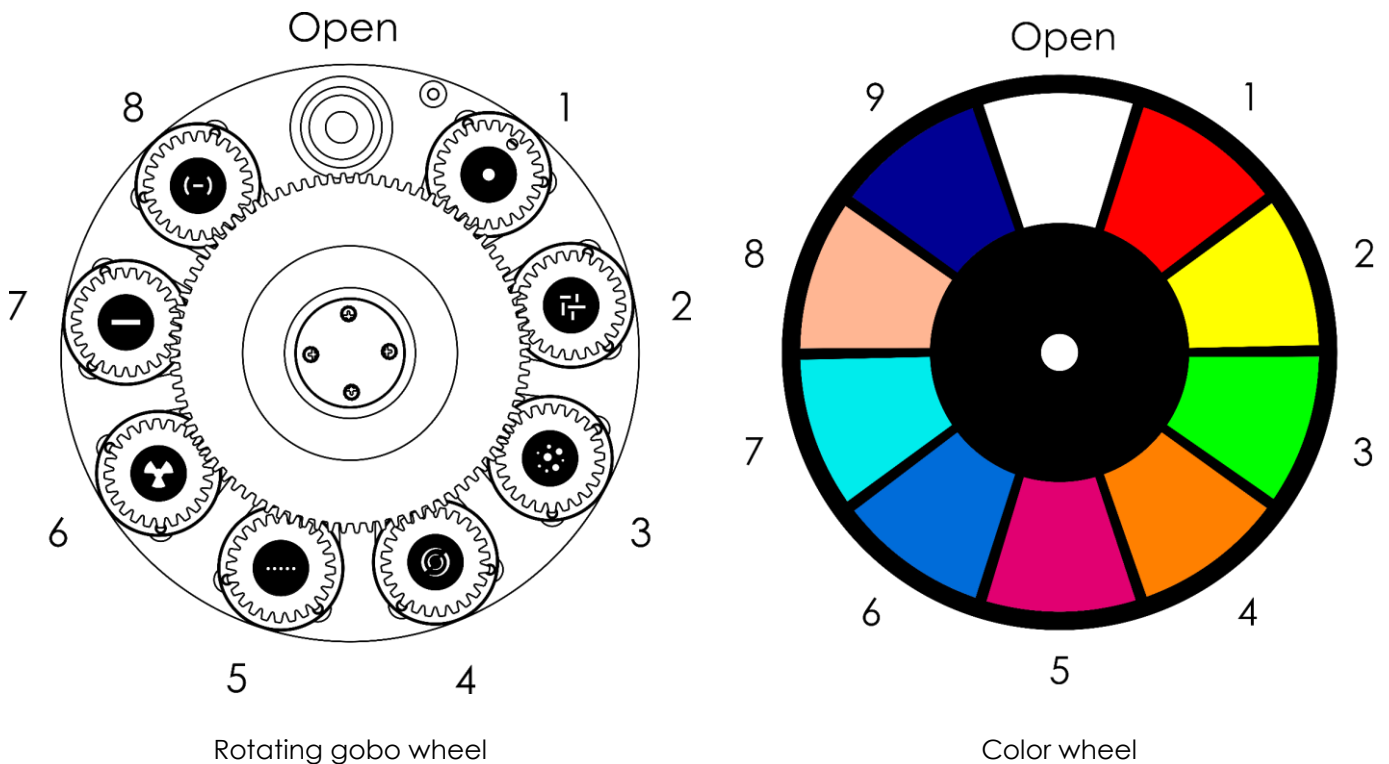

Fig. 13

Note: The gobos on the rotating gobo wheel are not replaceable.

Troubleshooting

This troubleshooting guide is meant to help solve simple problems.

If a problem occurs, carry out the steps below in sequence until a solution is found. Once the unit operates properly, do not carry out following steps.

No Light

If the light effect does not operate properly, refer servicing to a technician.

Suspect three potential problem areas as: the power supply, the LEDs, the fuse.

- 01) Power supply. Check if the unit is plugged into an appropriate power supply.
- 02) The LEDs. Return the Polar to your Showtec dealer.
- 03) The fuse. Replace the fuse. See page 43 for replacing the fuse.
- 04) If all of the above appears to be OK, plug the unit in again.
- 05) If you are unable to determine the cause of the problem, do not open the Polar, as this may damage the unit and the warranty will become void.
- 06) Return the device to your Showtec dealer.

No Response to DMX

Suspect the DMX cable or connectors, a controller malfunction, a light effect DMX card malfunction.

- 01) Check the DMX settings. Make sure that DMX addresses are correct.
- 02) Check the DMX cable: Unplug the unit; change the DMX cable; then reconnect to electrical power. Try your DMX control again.
- 03) Determine whether the controller or light effect is at fault. Does the controller operate properly with other DMX products? If not, take the controller in for repair. If so, take the DMX cable and the light effect to a qualified technician.

Problem	Probable cause(s)	Solution
One or more fixtures do not function at all	No power to the fixture	<ul style="list-style-type: none"> • Check if power is switched on and cables are plugged in
	Primary fuse blown	<ul style="list-style-type: none"> • Replace fuse
Fixtures reset correctly, but all respond erratically or not at all to the controller	The controller is not connected	<ul style="list-style-type: none"> • Connect controller
	5-pin DMX OUT of the controller does not match DMX IN of the first fixture on the link (i.e. signal is reversed)	<ul style="list-style-type: none"> • Install a phase reversing cable between the controller and the first fixture on the link
Fixtures reset correctly, but some respond erratically or not at all to the controller	Poor data quality	<ul style="list-style-type: none"> • Check data quality. If much lower than 100 percent, the problem may be a bad data link connection, poor quality or broken cables, missing termination plug, or a defective fixture disturbing the link
	Bad data link connection	<ul style="list-style-type: none"> • Inspect connections and cables. Correct poor connections. Repair or replace damaged cables
	Data link not terminated with 120 Ohm termination plug	<ul style="list-style-type: none"> • Insert termination plug in output jack of the last fixture on the link
	Incorrect addressing of the fixtures	<ul style="list-style-type: none"> • Check address settings
	One of the fixtures is defective and disturbs data transmission on the link	<ul style="list-style-type: none"> • Bypass one fixture at a time until normal operation is regained: unplug both connectors and connect them directly together • Have the defective fixture serviced by a qualified technician
	5-pin DMX OUT on the fixtures does not match (pins 2 and 3 reversed)	<ul style="list-style-type: none"> • Install a phase-reversing cable between the fixtures or swap pin 2 and 3 in the fixture, that behaves erratically
No light or LEDs cut out intermittently	Fixture is too hot	<ul style="list-style-type: none"> • Allow fixture to cool • Clean the fan • Make sure air vents are not blocked • Turn up the air conditioning
	LEDs damaged	<ul style="list-style-type: none"> • Disconnect fixture and return to your dealer
	The power supply settings do not match local AC voltage and frequency	<ul style="list-style-type: none"> • Disconnect fixture. Check settings and correct if necessary

Product Specifications

Model:	Polar 100 Beam IP65 Moving Head
Input voltage:	100–240 V AC, 50/60 Hz
Power consumption:	180 W
DMX linking:	30 pcs
Fuse:	T6,3 A/250 V
Dimensions:	482 x 410 x 295 mm (L x W x H)
Weight:	19,7 kg

Operating and Programming:

Signal pin OUT:	Pin 1 (earth), pin 2 (-), pin 3 (+), pin 4 (N/C), pin 5 (N/C)
DMX Mode:	12 channels (Basic), 15 channels (Standard), 18 channels (Extended)
Signal input:	5-pin DMX IN
Signal output:	5-pin DMX OUT

Electro-mechanical properties:

Light source:	100 W LED Module
Light output:	170000 Lux @ 5 m
Focus:	Motorized linear focus
Beam angle:	1,7°
Dimmer:	0–100% (16 bit)
Strobe:	0–25 Hz
DMX control:	Via standard DMX controller
Onboard:	LCD display, battery-powered
Control:	Stand alone, Manual, Master/Slave, DMX-512, Art-Net/sACN, W-DMX
Pan:	0°–540°
Tilt:	0°–270°
Special:	Pan/tilt movement blackout, user selectable Pan/Tilt ranges, reverse Pan/Tilt movement
Pan/Tilt resolution:	8–16 bit
Color wheel:	9 dichroic filters + white
Color functions:	Rainbow flow effect, color split
Rotating gobo wheel:	8 rotating gobos + open
Gobo functions:	Gobo flow effect, gobo shake, gobo bounce, bidirectional rotation
Prism:	1 x 5-facet linear and 1 x 24-facet circular prisms
Prism functions:	Bidirectional rotation, adjustable speed, prism overlay
Housing:	Flame-retardant plastic, die-cast aluminum
Color:	Black
IP rating:	IP-65
Connections:	IP-65 rated power connectors True 1 IN/OUT, IP-65 rated 5-pin DMX IN/OUT connectors, 2 x IP-65 rated RJ45 connectors
Cooling:	Natural radiation

Max. ambient temperature t_a :	40 °C
Max. housing temperature t_B :	70 °C

Minimum distance:

Minimum distance from flammable surfaces:	1,3 m
Minimum distance to lighted object:	1,3 m

Design and product specifications are subject to change without prior notice.



Website: www.Showtec.info
 Email: service@highlite.com

Dimensions

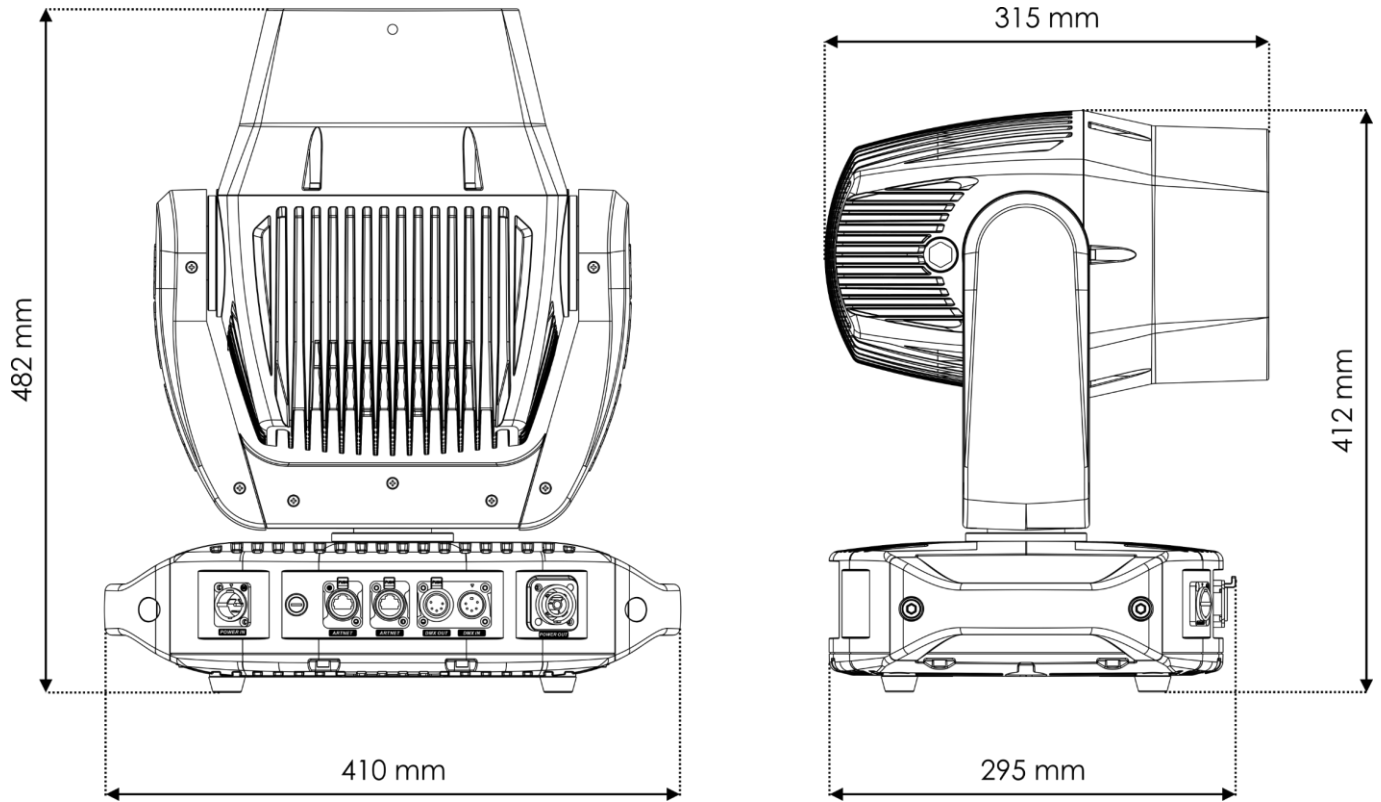



©2020 Showtec