

ENGLISH

RainDome 40 cm

V1

Product code: 71325

Preface

Thank you for purchasing this Showgear product.

The purpose of this user manual is to provide instructions for the correct and safe use of this product.

Keep the user manual for future reference as it is an integral part of the product. The user manual shall be stored at an easily accessible location.

This user manual contains information concerning:

- Safety instructions
- Installation and operation of the device
- Intended and non-intended use of the device
- Maintenance procedures
- Troubleshooting
- Transport, storage and disposal of the device

Non-observance of the instructions in this user manual may result in serious injuries and damage of property.

©2022 Showgear. All rights reserved.

No part of this document may be copied, published or otherwise reproduced without the prior written consent of Highlite International.

Design and product specifications are subject to change without prior notice.

For the latest version of this document or other language versions, please visit our website www.highlite.com or contact us at service@highlite.com.

Highlite International and its authorized service providers are not liable for any injury, damage, direct or indirect loss, consequential or economic loss or any other loss arising from the use of, or inability to use or reliance on the information contained in this document.

Table of contents

1. Introduction	3
1.1. Before Using the Product	3
1.2. Intended Use	3
1.3. Product Lifespan.....	3
1.4. Text Conventions	3
1.5. Symbols and Signal Words.....	4
1.6. Symbols on the Information Label	4
2. Safety	5
2.1. Warnings and Safety Instructions	5
2.2. Requirements for the User.....	7
3. Description of the Device	8
3.1. Top Plate View	8
3.2. Side View	8
3.3. Bottom Plate View.....	9
3.4. Product Specifications	9
3.5. Accessories.....	10
3.6. Dimensions.....	10
4. Installation	11
4.1. Safety Instructions for Installation	11
4.1. Personal Protective Equipment	11
4.2. Installation Site Requirements	11
4.3. Rigging	11
5. Setup and Operation	14
5.1. Warnings and Precautions	14
5.2. Compatibility of the Device.....	15
5.3. Setup.....	16
5.4. Connecting a Stage Luminaire to the Device	16
5.5. Installing the Plastic Sleeve.....	17
5.6. Connecting to Power Supply.....	18
5.7. Power Linking of Multiple Devices.....	18
5.8. Operation	19
5.9. Using the Bypass Function	19
6. Troubleshooting	20
7. Maintenance	20
7.1. Safety Instructions for Maintenance.....	20
7.2. Preventive Maintenance	20
7.2.1. Basic Cleaning Instructions	21
7.3. Corrective Maintenance	21
8. Deinstallation, Transportation and Storage	21
8.1. Instructions for Deinstallation.....	21
8.2. Instructions for Transportation	21
8.3. Storage.....	21
9. Disposal	22
10. Approval	22

1. Introduction

1.1. Before Using the Product



Important

Read and follow the instructions in this user manual before installing, operating or servicing this product.

The manufacturer will not accept liability for any resulting damages caused by the non-observance of this manual.

After unpacking, check the contents of the box. If any parts are missing or damaged, contact your Highlite International dealer.

Your shipment includes:

- Showgear RainDome 40 cm
- Schuko to pro power True1 power cable (1,5 m)
- User manual

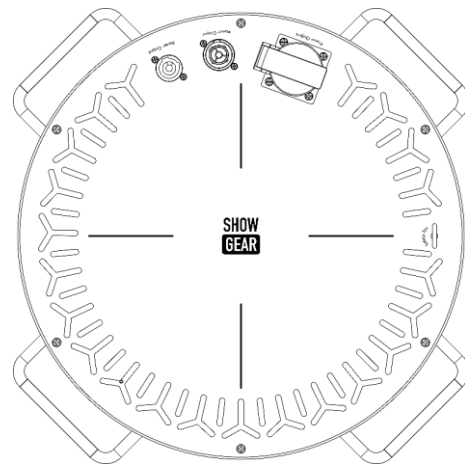

Fig. 01

1.2. Intended Use

This device is intended for professional use as a rain cover platform for stage luminaires. This device shall be used only in combination with the recommended plastic sleeves. It is suitable for outdoor use only when in operation and with the plastic sleeve installed. The device is not suitable for households.

Any other use, not mentioned under intended use, is regarded as non-intended and incorrect use.

1.3. Product Lifespan

This device is not designed for permanent operation. Disconnect the device from the electrical power supply when the device is not in operation. This will reduce the wear and will improve the device's lifespan.

1.4. Text Conventions

Throughout the user manual the following text conventions are used:

- Buttons: All buttons are in bold lettering, for example "Press the **UP/DOWN** buttons"
- References: References to chapters and parts of the device are in bold lettering, for example: "Refer to **2. Safety**", "turn the **adjustment screw (02)**"
- 0–255: Defines a range of values
- Notes: **Note:** (in bold lettering) is followed by useful information or tips

1.5. Symbols and Signal Words

Safety notes and warnings are indicated throughout the user manual by safety signs.

Always follow the instructions provided in this user manual.



DANGER

Indicates an imminently hazardous situation which, if not avoided, will result in death or serious injury.



WARNING

Indicates a potentially hazardous situation which, if not avoided, could result in death or serious injury.



CAUTION

Indicates a potentially hazardous situation, which, if not avoided, may result in minor or moderate injury.



Attention

Indicates important information for the correct operation and use of the product.



Important

Read and observe the instructions in this document.



Electrical hazard



Provides important information about the disposal of this product.

1.6. Symbols on the Information Label

This product is provided with an information label. The information label is located on the backside of the device.

The information label contains the following symbols:



This device shall not be treated as household waste.



This device is designed for indoor use.



Read and observe the instructions in the user manual.



This device falls under IEC protection class I.

2. Safety



Important
Read and follow the instructions in this user manual before installing, operating or servicing this product.

The manufacturer will not accept liability for any resulting damages caused by the non-observance of this manual.

2.1. Warnings and Safety Instructions



DANGER
Danger for children

For adult use only. The device must be installed beyond the reach of children.

- Do not leave various parts of the packaging (plastic bags, polystyrene foam, nails, etc.) within children's reach. Packaging material is a potential source of danger for children.



DANGER
Electric shock caused by dangerous voltage inside

There are areas within the device where dangerous touch voltage may be present.

- Do not open the device or remove any covers.
- Do not operate the device if the covers or the housing are open. Before operation, check if the housing is firmly closed and all screws are tightly fastened.
- Disconnect the device from electrical power supply before service and maintenance, and when the device is not in use.



DANGER
Electric shock caused by short-circuit

This device falls under IEC protection class I.

- Make sure that the device is electrically connected to ground (earth). Connect the device only to a socket-outlet with ground (earth) connection.
- Do not cover the ground (earth) connection.
- Do not bypass the thermostatic switch or fuses.
- Do not let the power cable come into contact with other cables. Handle the power cable and all connections with the mains with caution.
- Do not modify, bend, mechanically strain, put pressure on, pull or heat up the power cable.
- Make sure that the power cable is not crimped or damaged. Examine the power cable periodically for any defects.
- Do not immerse the device in water or other liquids. Do not install the device in a location where flooding may occur.
- Do not use the device during thunderstorms. Disconnect the device from the electrical power supply immediately.
- Keep the connectors sealed with the rubber caps when the connectors are not in use.
- Do not connect the cables from above the connectors, if the device is installed outdoors. Make a 'drip loop' in the cable so that rain water cannot enter the device.



Attention **Power supply**

- Before connecting the device to the power supply, make sure that the current, voltage and frequency match the input voltage, current and frequency specified on the information label on the device.
- Make sure that the cross-sectional area of the extension cords and power cables is sufficient for the required power consumption of the device.



Attention **General safety**

- Do not insert objects into the air vents.
- Do not shake the device. Avoid brute force when installing or operating the device.
- If the device is dropped or struck, disconnect the device from the electrical power supply immediately.
- If the device is exposed to extreme temperature variations (e.g. after transportation), do not switch it on immediately. Let the device reach room temperature before switching it on, otherwise it may be damaged by the formed condensation.
- If the device fails to work properly, discontinue the use immediately.



Attention **For professional use only** **This device shall be used only for the purposes it is designed for.**

This device is intended for professional use as a rain cover platform for stage luminaires. This device shall be used only in combination with the recommended plastic sleeves. It is suitable for outdoor use. The device is not suitable for households.

Any incorrect use may lead to hazardous situations and result in injuries and material damage.

- This device is not suitable for households.
- This device is not designed for permanent operation.
- This device does not contain user-serviceable parts. Unauthorized modifications to the device will render the warranty void. Such modifications may result in injuries and material damage.



Attention **Before each use, examine the device visually for any defects.**

Make sure that:

- All screws used for installing the device or parts of the device are tightly fastened and are not corroded.
- The safety devices are not damaged.
- There are no deformations on housings, fixations and installation points.
- The power cables are not damaged and do not show any material fatigue.



Attention

Do not expose the device to conditions that exceed the rated IP class conditions.

This device is IP20 rated. IP (Ingress Protection) 20 class provides protection against solid objects greater than 12 mm, such as fingers, and no protection against harmful ingress of water.

When the device is fitted with the plastic sleeve and in operation, the top part of the device is IP54. IP54 class means that the device is protected against dust and harmful effect of water splashes from any direction. The ingress protection of the bottom part of the device remains IP20 class.

2.2. Requirements for the User

This product may be used by ordinary persons. Maintenance may be carried by ordinary persons. Installation and service shall be carried out only by instructed or skilled persons. Contact your Highlite dealer for more information.

Instructed persons have been instructed and trained by a skilled person, or are supervised by a skilled person, for specific tasks and work activities associated with the installation, service and maintenance of this product, so that they can identify risks and take precautions to avoid them.

Skilled persons have training or experience, which enables them to recognize risks and to avoid hazards associated with the installation, service and maintenance of this product.

Ordinary persons are all persons other than instructed persons and skilled persons. Ordinary persons include not only users of the product but also any other persons that may have access to the device or who may be in the vicinity of the device.

3. Description of the Device

The Showgear RainDome 40 cm is a rain cover platform for stage luminaires with a maximum diameter of 40 cm. The device protects stage luminaires from rainfall which makes it possible to use indoor stage luminaires outdoors. The device has a built-in pressure sensor which turns the device off when the inner pressure decreases. The device is equipped with IP-rated True1 power input and output connectors. It is possible to power stage luminaires by connecting them to one of the 3 output connectors (pro power, pro power True1 and Schuko).

3.1. Top Plate View

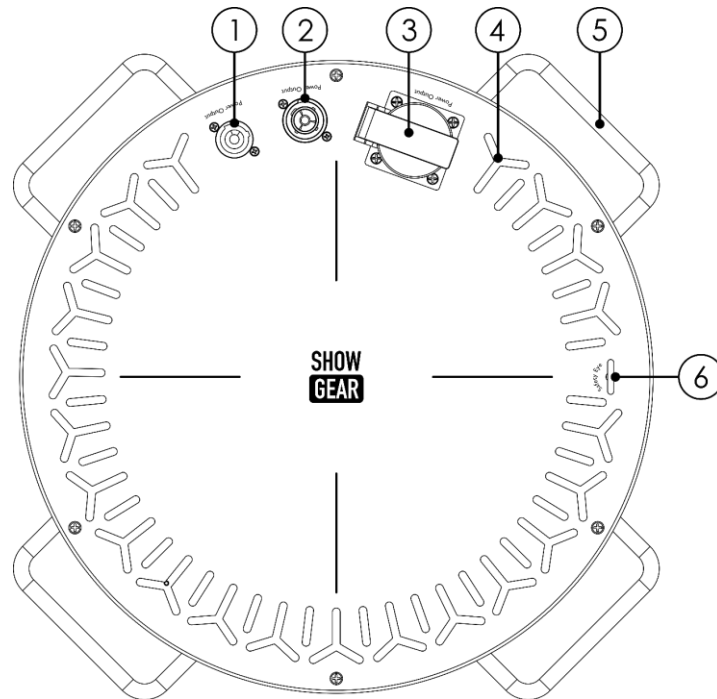

Fig. 02

- 01) Pro power connector OUT (Gray): to power stage luminaires
- 02) Pro power True1 connector OUT: to power stage luminaires
- 03) Schuko power connector OUT: to power stage luminaires
- 04) Air outlets
- 05) 4 x carrying handles
- 06) Safety eye for stage luminaires

3.2. Side View

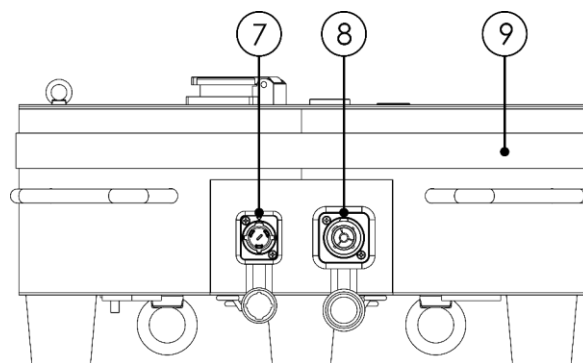

Fig. 03

- 07) IP-rated pro power True1 connector IN: to power the device
- 08) IP-rated pro power True1 connector OUT: to daisy-chain the device
- 09) Hook-and-loop fastener

3.3. Bottom Plate View

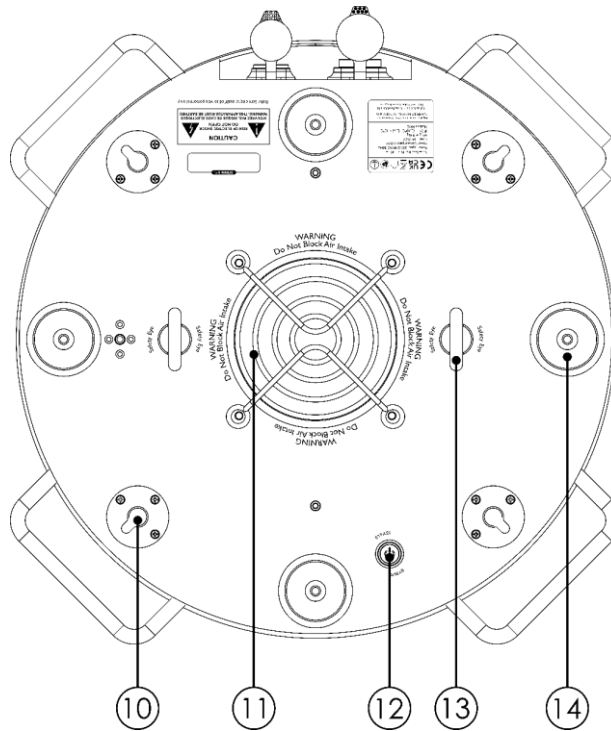

Fig. 04

- 10) 4 x mounting holes (M12)
- 11) Air intake
- 12) Bypass switch (See **5.9. Using the Bypass Function** on page 19)
- 13) 2 x safety eyes
- 14) 4 x rubber feet

3.4. Product Specifications

Model:	RainDome 40 cm
Electrical:	
Input voltage:	220–240 V AC, 50 Hz
Power consumption:	126 W
Power connector IN:	IP-rated pro power True1 connector IN
Power connector OUT:	IP-rated pro power True1 connector OUT
Stage luminaire power connectors OUT:	<ul style="list-style-type: none"> • Pro power connector OUT (Gray) • Pro power True1 connector OUT • Schuko power connector OUT
Physical:	
Maximum load:	40 kg
Dimensions:	476 x 476 x 184 mm (LxWxH)
Weight:	9,3 kg
Construction:	
Housing:	Steel
Color:	Black
IP rating:	IP54 (with plastic sleeve); IP20 (without plastic sleeve)
Thermal:	
Maximum ambient temperature t_a :	40 °C
Maximum housing temperature t_c :	40 °C

3.5. Accessories



Attention

The device is designed to be operated with the plastic sleeve installed.

The device is delivered without a plastic sleeve. Refer to **5.2. Compatibility of the Device** on page 15. There is 1 plastic sleeve available for this device:

- Product code: [71326](#) (Cylindric Sleeve for RD40; Max. height: 52 cm)

The device can be mounted to a totem truss. To mount the device to the totem truss, you need to purchase 4 connectors. Use the connectors suitable for your truss. Choose one out of the following connector sorts:

- Product code: [CON63](#) (Half Connector Male PQ + pin)
- Product code: [CON63F](#) (Half Connector Male FQ + pin)
- Product code: [CON63U](#) (Half Connector Male GQ + pin)

3.6. Dimensions

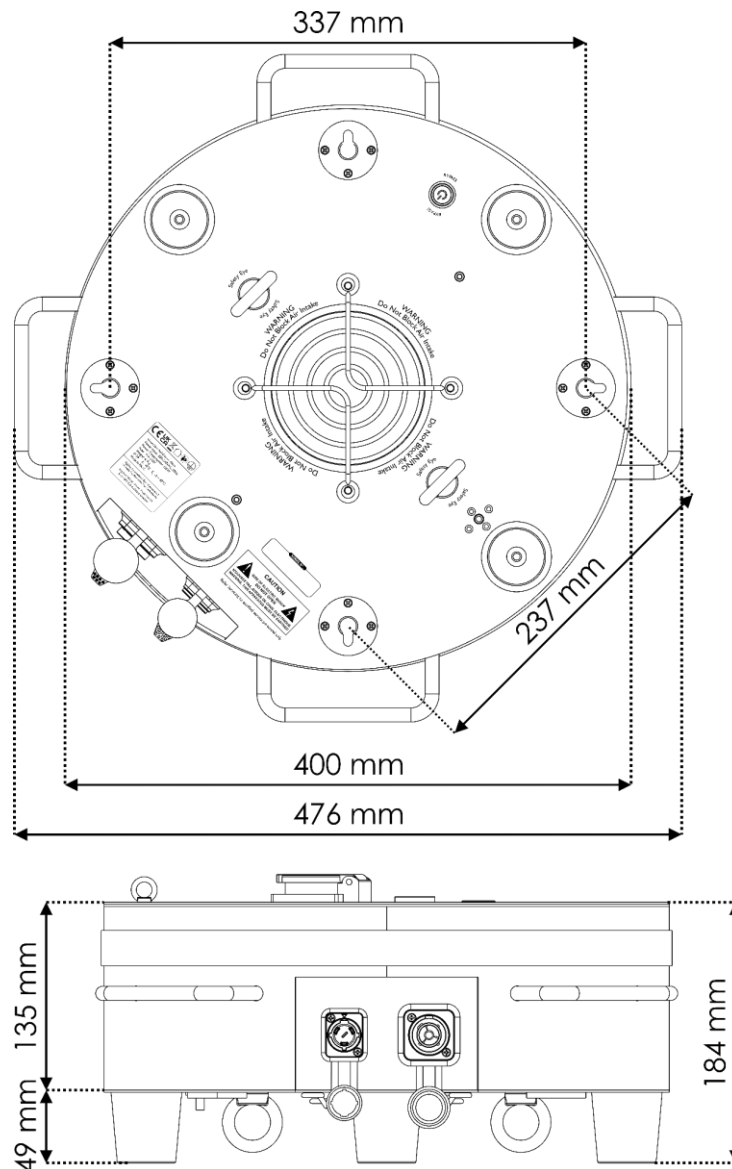

Fig. 05

4. Installation

4.1. Safety Instructions for Installation



WARNING

Incorrect installation can cause serious injuries and damage of property.

If trussing systems are used, installation must be carried out only by instructed or skilled persons.

Follow all applicable European, national and local safety regulations concerning rigging and trussing.

4.1. Personal Protective Equipment

During installation and rigging wear personal protective equipment in compliance with the national and site-specific regulations.

4.2. Installation Site Requirements

- The device can be used outdoors only when in operation and with the plastic sleeve installed.
- The device can only be positioned on a flat surface or mounted to a totem truss in horizontal orientation, with the top side facing up.
- The maximum ambient temperature $t_a = 40\text{ °C}$ must never be exceeded.

4.3. Rigging



CAUTION

Restrict the access under the work area during rigging and/or derigging.

The device can be positioned on a flat surface or mounted to a truss in horizontal orientation. The device is suitable for mounting to a vertically positioned totem truss. Make sure that all loads are within the pre-determined limits of the supporting structure.

- Do not install the device in a position that is not recommended in this user manual.
- Make sure that the device is installed on a levelled surface.

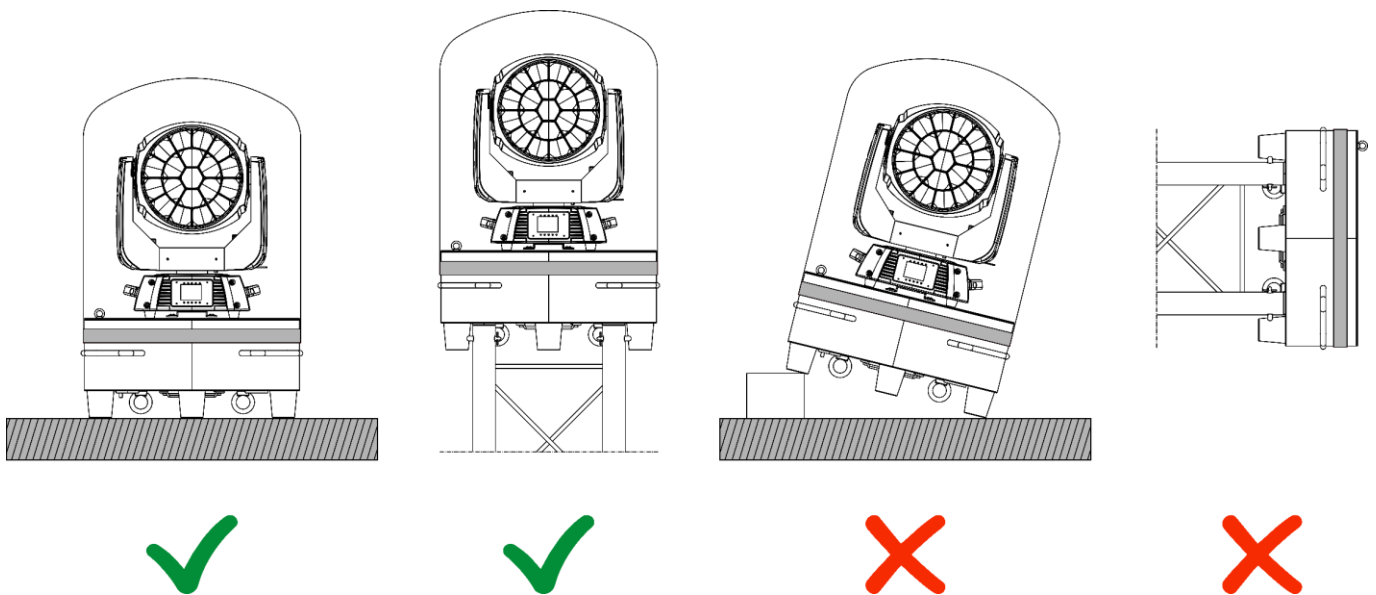

Fig. 06

To mount the device to a totem truss you need the following items:

- 4 x half connectors (A) (including washers (B) and bolts (C)). See **3.5. Accessories** on page 10, for more information.
- 4 x conical pins (D) (Not included. Refer to your totem truss dealer for availability.)
- 4 x safety springs (E) (Not included. Refer to your totem truss dealer for availability.)

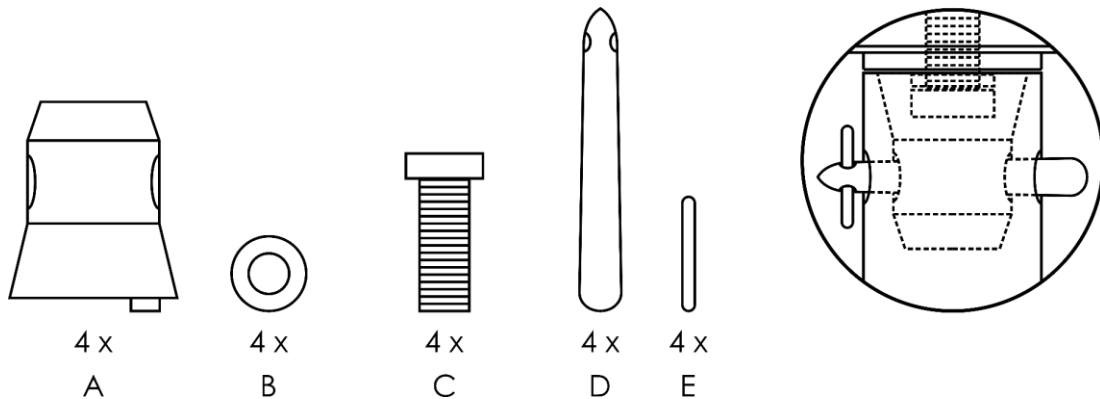

Fig. 07

To mount the device to a truss, follow the steps below:

- 01) Put the 4 half connectors (A) into the **mounting holes (10)** as shown in Fig. 08.

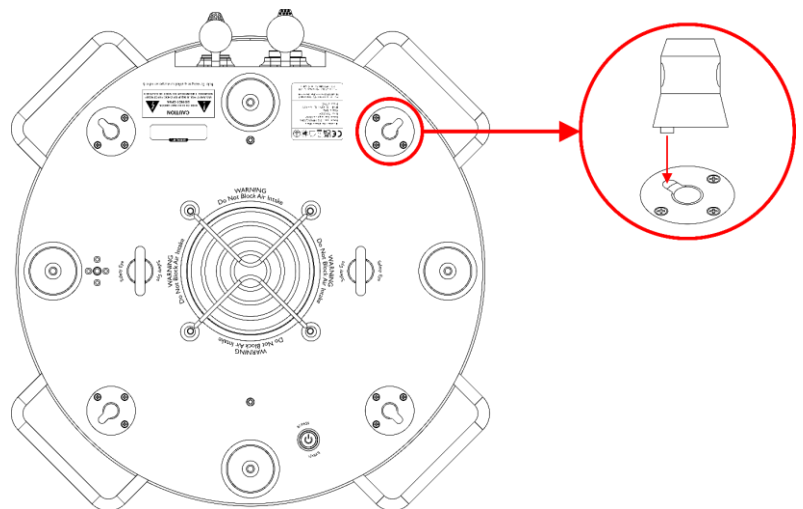

Fig. 08

- 02) Put the washers (B) and the bolts (C) into the half connectors (A), as shown in Fig. 09.

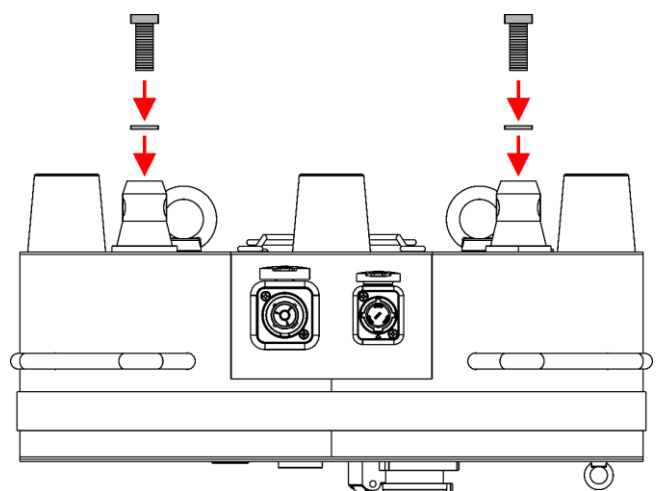

Fig. 09

- 03) Tighten the bolts with a hex key (8 mm) as shown in Fig. 10.

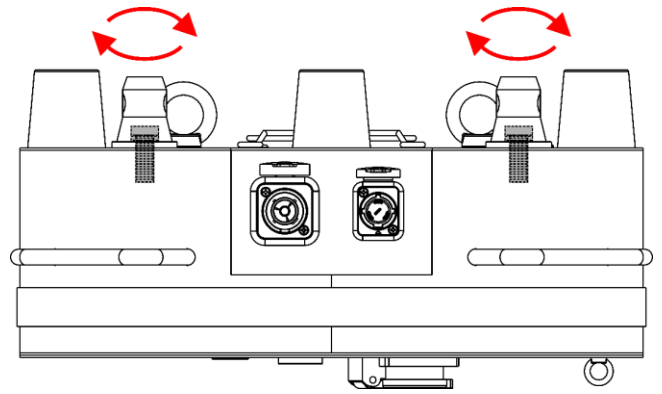

Fig. 10

- 04) Put the device on the truss, so that the half connectors (A) fit in the tubes of the truss, as shown in Fig. 11.

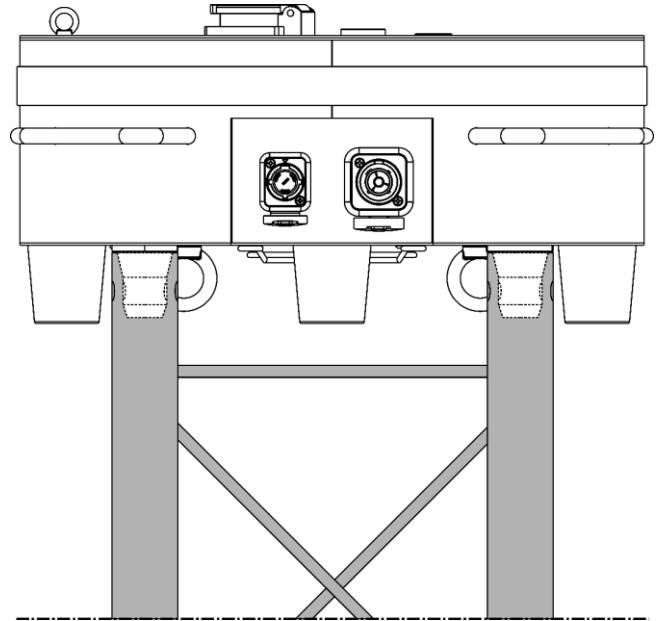

Fig. 11

- 05) Put the conical pins (D) into the openings on the truss and through the half connectors (A), as shown in Fig. 12.
- 06) Put the safety pins (E) into the opening on the conical pins (D) to secure the device to the truss, as shown in Fig. 12.

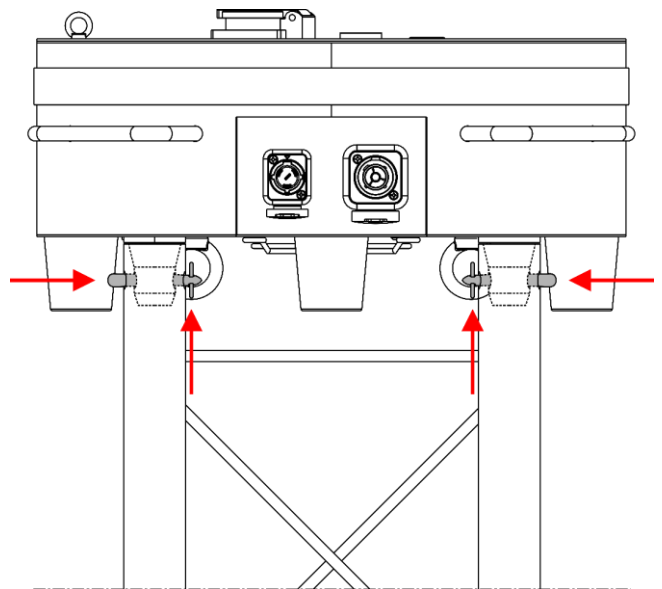

Fig. 12

07) Secure the device with a secondary suspension, for example a safety cable as shown in Fig. 13. Put the safety cable through the **safety eye (13)**.

Note:

Make sure that the secondary suspension can hold 10 times the weight of the device. If possible, the secondary suspension should be attached to a supporting structure independent of the primary suspension.

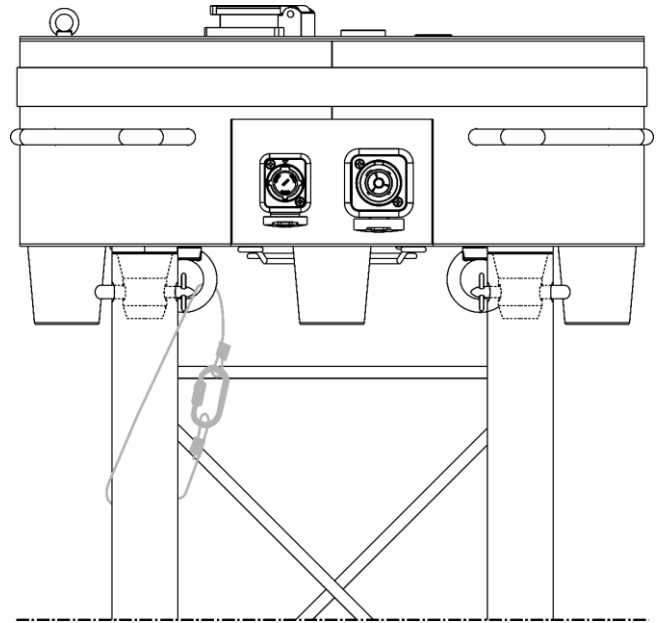

Fig. 13

5. Setup and Operation

5.1. Warnings and Precautions



Attention

This device must be used only for the purposes it is designed for.

This device is intended for professional use as a rain cover platform for stage luminaires. This device shall be used only in combination with the recommended plastic sleeve. It is suitable for outdoor use, only when in operation and with the plastic sleeve installed.

- Do not operate the device outdoors without the plastic sleeve installed. If you operate the device without the plastic sleeve, the device has an IP20 class.
- Do not operate the device if the plastic sleeve is not fully inflated.
- Do not operate the device in setups that are not recommended in this user manual.

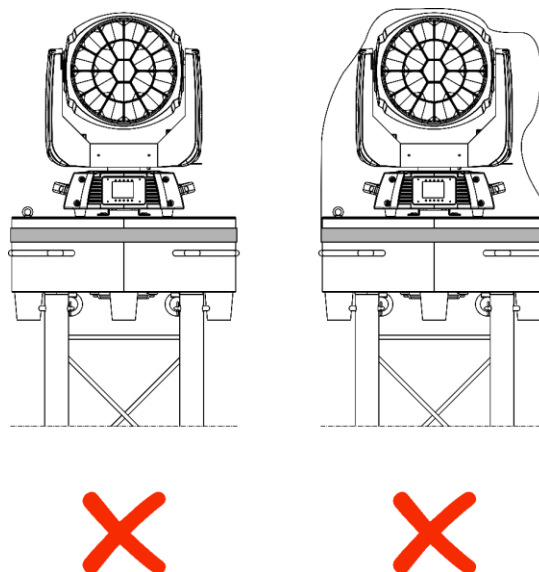

Fig. 14



Attention
Connect all cables before supplying power.
Disconnect power supply before connecting or disconnecting cables.

5.2. Compatibility of the Device

This device can be used only with stage luminaires that have:

- a maximum diameter of 40 cm
- a maximum height of 52 cm (in combination with the Cylindrical Sleeve for Rain Dome 40 (71326)). See Fig. 15 on page 15 for more information.
- a total weight of 40 kg
- a LED light source

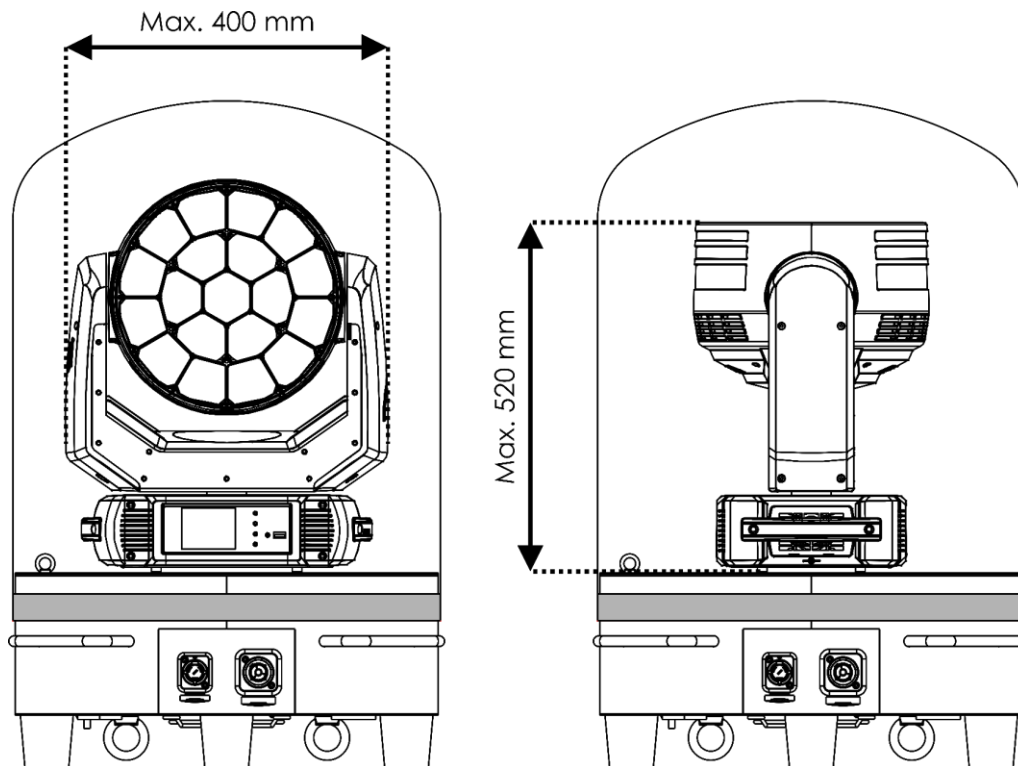

Fig. 15

Do not use the device with:

- lasers
- moving heads equipped with lasers
- moving heads with discharge lamps

5.3. Setup

To complete the setup of the device, follow the steps below:

- 01) Install the device. See **4. Installation** on page 11 for more information.
- 02) Connect a stage luminaire. See **5.4. Connecting a Stage Luminaire to the Device** on page 16 for more information.
- 03) Install the plastic sleeve. See **5.5. Installing the Plastic Sleeve** on page 17 for more information.
- 04) Connect the device to power supply. See **5.6. Connecting to Power Supply** on page 18 for more information.

5.4. Connecting a Stage Luminaire to the Device

To connect a stage luminaire, follow the steps below:

- 01) Put the stage luminaire in the middle of the top plate of the RainDome.
- 02) Secure the stage luminaire with a secondary suspension, for example a safety cable. Make sure that the secondary suspension can hold 10 times the weight of the device. Put the safety cable through the **safety eye (06)**.
- 03) Install the plastic sleeve. See **5.5. Installing the Plastic Sleeve** on page 17 for more information.
- 04) Put DMX cables through the hook-and-loop fastener opening on the plastic sleeve, so that the DMX connectors are protected from ingress of water (Fig. 16).
- 05) Connect the DMX cables to the input and output connectors of the stage luminaire.

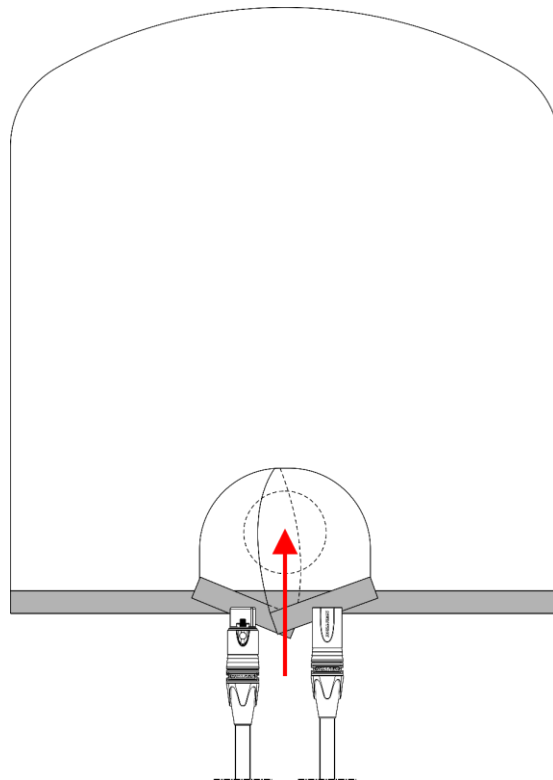

Fig. 16

- 06) Connect the stage luminaire to the device with a power cable.

5.5. Installing the Plastic Sleeve



Attention

The device is designed to be operated only with the plastic sleeve installed.

This device can be fitted with the Cylindrical sleeve for Rain Dome 40 (71326), for stage luminaires with a maximum height of 52 cm.

See **3.5. Accessories** on page 10, for more information.

To install the plastic sleeve, follow the steps below:

- 01) Put the plastic sleeve over the device (Fig. 17).
- 02) Attach the hook-and-loop fastener of the plastic sleeve to the **hook-and-loop fastener (09)** of the device and press it tightly (Fig. 18).

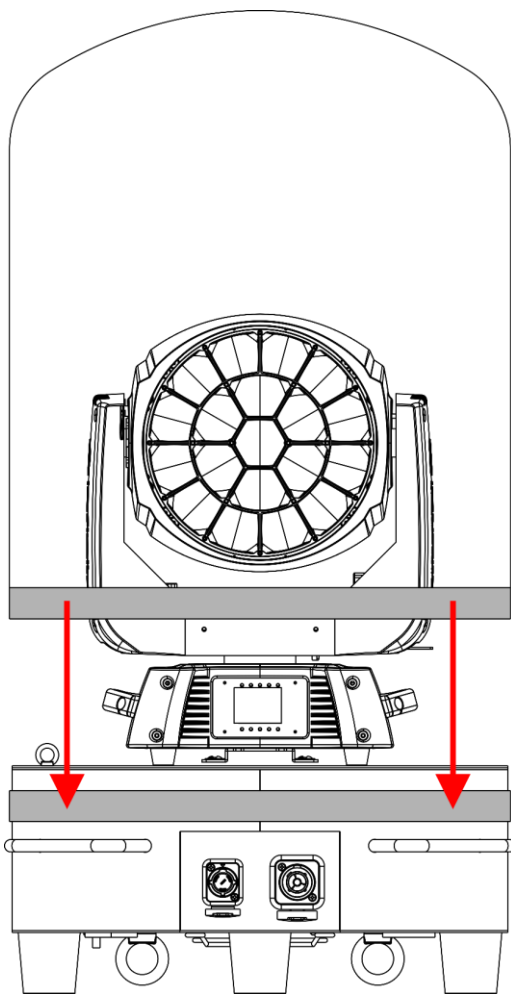

Fig. 17

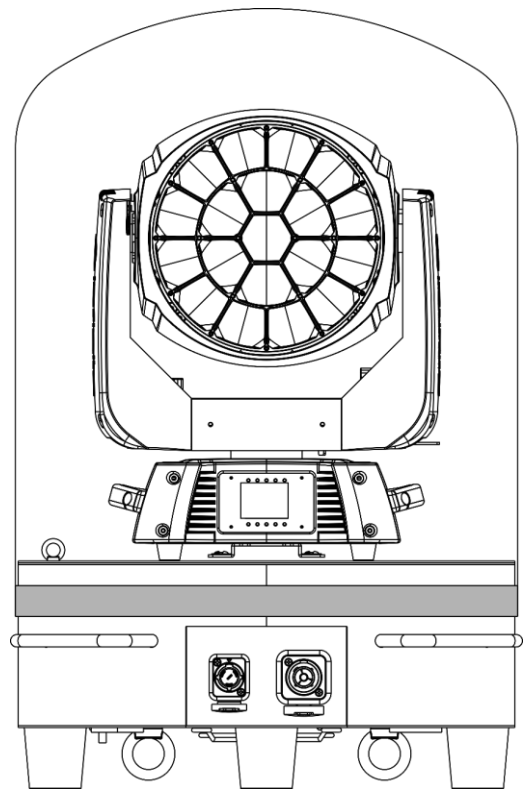

Fig. 18

Note:

Make sure that the hook-and-loop fastener of the plastic sleeve is attached tightly to the **hook-and-loop fastener (09)** on the device. If there is an opening along the attached hook-and-loop fasteners, the sleeve will not inflate correctly.

5.6. Connecting to Power Supply

When the device is connected to power supply, the device is in operation. The fan starts rotating and the installed plastic sleeve becomes inflated.



DANGER
Electric shock caused by short-circuit

The device accepts AC mains power at 220–240 V and 50 Hz. Do not supply power at any other voltage or frequency to the device.

This device falls under IEC protection class I. Make sure that the device is always electrically connected to the ground (earth).

Before connecting the device to the socket-outlet:

- Make sure that the power supply matches the input voltage specified on the information label on the device.
- Make sure that the socket-outlet has ground (earth) connection.

Connect the device to the socket-outlet with the power plug.

When the device is fitted with the plastic sleeve and in operation, the top part of the device is IP54. Do not expose the device to conditions that exceed the rated IP class conditions.

- Keep the connectors sealed with the rubber caps when the connectors are not in use.
- Do not connect the cables from above the connectors, if the device is installed outdoors. Make a 'drip loop' in the cable so that rain water cannot enter the device.
- Make sure that the cable run is not too heavy. A heavy cable run can cause damage to the connectors. If the connectors are damaged, their ingress protection (IP) can deteriorate.

5.7. Power Linking of Multiple Devices

This device supports power linking. Power can be relayed to another device and to the connected stage luminaire via the power OUT connectors. Note that the input and the output connectors have different designs: one type cannot be connected to the other.

Power linking of multiple devices must be carried out only by instructed or skilled persons.



WARNING
Incorrect power linking may lead to overload of the electrical circuit and result in serious injuries and damage of property.

To prevent overload of the electrical circuit, when power linking multiple devices:

- Use cables with sufficient current-carrying capacity. The power cable supplied with the device is not suitable for power linking of multiple device.
- Keep the connectors sealed with the rubber caps when the connectors are not in use.
- Make sure that the total current draw of the device and all connected devices does not exceed the rated capacity of the power cables and the circuit breaker.
- Do not link more devices on one power link than the maximum recommended number.

The maximum recommended number of devices depends on the total load of all linked RainDomes and stage luminaires. The total load of all linked RainDomes and stage luminaires shall not exceed 3000 W.

5.8. Operation

When the device is connected to power supply, the device is in operation. The fan starts rotating and the installed plastic sleeve becomes inflated.

- To turn the device on, connect the device to power supply. See **5.6. Connecting to Power Supply** on page 18 for more information.
- To turn the device off, disconnect the device from power supply.

5.9. Using the Bypass Function

The device has a built-in pressure sensor. If the pressure decreases in the inflated plastic sleeve during operation, the sensor disconnects the 3 power output connectors: **pro power connector OUT (01)**, **pro power True1 connector OUT (02)** and **Schuko power connector OUT (03)**. The stage luminaire powered by one of those connectors turns off.

To adjust the settings of the connected stage luminaire, you can use the **bypass switch (12)**. The **bypass switch (12)** temporarily deactivates the built-in air pressure sensor.



Attention
Risk of damage to property

If the stage luminaire has a moving head, the plastic sleeve and the stage luminaire may become damaged if the stage luminaire moves when the plastic sleeve is not fully inflated.

Make sure that the stage luminaire is not moving while you are adjusting its settings. If the plastic sleeve is not fully inflated it can be caught by the moving head of the stage luminaire.

To use the bypass function, follow the steps below:

- 01) Press and hold down the **bypass switch (12)**.
- 02) Adjust the settings on the stage luminaire through the plastic sleeve. Do not remove the plastic sleeve.
- 03) Wait until the plastic sleeve is fully inflated again.
- 04) Release the **bypass switch (12)**.

6. Troubleshooting

This troubleshooting guide contains solutions to problems which can be carried out by an ordinary person. The device does not contain user-serviceable parts.

Unauthorized modifications to the device will render the warranty void. Such modifications may result in injuries and material damage.

Refer servicing to instructed or skilled persons. Contact your Highlite International dealer in case the solution is not described in the table.

Problem	Probable cause(s)	Solution
The device does not function at all	No power to the device	<ul style="list-style-type: none"> Check if power is switched on and cables are plugged in
	Internal fuse is blown	<ul style="list-style-type: none"> Return the device to your Showgear dealer
	The power supply settings do not match local AC voltage and frequency	<ul style="list-style-type: none"> Disconnect the device. Check the settings and correct, if necessary
The stage luminaire does not function at all	No power to the stage luminaire	<ul style="list-style-type: none"> Check if cables are plugged into the stage luminaire Check if the plastic sleeve is installed correctly Check if the plastic sleeve is fully inflated Follow the instructions from the user manual of the stage luminaire
The plastic sleeve does not inflate correctly	The plastic sleeve is damaged	<ul style="list-style-type: none"> Return the plastic sleeve to your Showgear dealer Install a new plastic sleeve
	The plastic sleeve is not installed correctly	<ul style="list-style-type: none"> Check if the hook-and-loop fastener of the plastic sleeve is attached tightly to the hook-and-loop fastener (09) of the device, without openings

7. Maintenance

7.1. Safety Instructions for Maintenance



DANGER
Electric shock caused by dangerous voltage inside

Disconnect power supply before servicing or cleaning.

7.2. Preventive Maintenance



Attention
Before use, examine the device visually for any defects.

Make sure that:

- All screws used for installing the device or parts of the device are tightly fastened and are not corroded.
- The safety devices are not damaged.

- There are no deformations on housings, fixations and installation points.
- The power cables are not damaged and do not show any material fatigue.

7.2.1. Basic Cleaning Instructions

To clean the device, follow the steps below:

- 01) Disconnect the device from the electrical power supply.
- 02) Allow the device to cool down for 5 minutes.
- 03) Clean the device with a soft, lint-free cloth.



Attention

- Do not immerse the device in liquid.
- Do not use alcohol or solvents.
- Make sure that the connections are fully dry before connecting the device to the power supply and to other devices.

7.3. Corrective Maintenance

The device does not contain user-serviceable parts. Do not open the device and do not modify the device.

Refer repairs and servicing to instructed or skilled persons. Contact your Highlite International dealer for more information.

8. Deinstallation, Transportation and Storage

8.1. Instructions for Deinstallation



WARNING

Incorrect deinstallation can cause serious injuries and damage of property.

- Let the device cool down before dismounting.
- Disconnect power supply before deinstallation.
- Always observe the national and site-specific regulations during deinstallation and derigging of the device.
- Wear personal protective equipment in compliance with the national and site-specific regulations.

8.2. Instructions for Transportation

- Use the original packaging to transport the device, if possible.
- Always observe the handling instructions printed on the outer carton box, for example: "Handle with care", "This side up", "Fragile".

8.3. Storage

- Clean the device before storing. Follow the cleaning instructions in chapter **7.2.1. Basic Cleaning Instructions** on page 21.
- Store the device in the original packaging, if possible.

9. Disposal

Correct disposal of this product

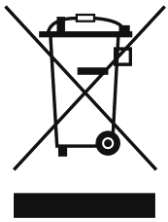

Waste Electrical and Electronic Equipment

This symbol on the product, its packaging or documents indicates that the product shall not be treated as household waste. Dispose of this product by handing it to the respective collection point for recycling of electrical and electronic equipment. This is to avoid environmental damage or personal injury due to uncontrolled waste disposal. For more detailed information about recycling of this product contact the local authorities or the authorized dealer.

10. Approval



Check the respective product page on the website of Highlite International (www.highlite.com) for an available declaration of conformity.

**SHOW
GEAR**

©2022 Showgear