

USER AND INSTALLATION MANUAL

MAG:CFX®

ENGLISH

/FLAMEBLAZER.®



FLAME FX

PART01875

rev 01-01

DISCLAIMER

⚠ WARNING

Read this manual carefully before installing and/or using this product. Failure to read the manual and to follow the printed instructions may lead to personal injury and/or damage to the product.

© 2020 MAGICFX®

All rights reserved.

Nothing from this publication may be copied, reproduced and/or published by means of printing, photocopying or by any other means, without the prior written approval of MAGIC FX.

MAGIC FX reserves the right to modify specifications stated in this manual.

TRADEMARKS

Any brand names mentioned in this manual are registered trademarks of their respective owners.

LIABILITY

MAGIC FX accepts no liability for claims from third parties arising from unauthorised use, use other than that stated in this manual, and use other than in accordance with the General Conditions registered at the Chamber of Commerce.

We further refer to the General Conditions. These are available on request, free of charge.

Although considerable care has been taken to ensure a correct and comprehensive description of all relevant components, the manual may nonetheless contain errors and inaccuracies.

Should you detect any errors or inaccuracies in the manual, we would be grateful if you would inform us. This helps us to further improve our documentation.

TABLE OF CONTENTS

Disclaimer	2
Trademarks	2
Liability	2
Foreword	4
Language	4
Revision table	4
1 Meet the FLAMEBLAZER®!	5
1.1 Main parts	6
1.2 MAGICFX FLAMEBLAZER® FUEL	6
1.3 Technical data	7
1.4 Product identification	8
1.5 Accessories	8
1.6 DMX control	9
1.7 Display panel	10
1.8 RDM capability	13
2 FLAME safely!	14
2.1 General safety rules	14
2.2 Rigging	14
2.3 Noise Levels	14
2.4 Safety symbols	15
2.5 Safety warnings	15
3 Let's Flame!	18
3.1 Install the machine	18
3.2 Choose the flame height	19
3.3 (Re)fill the Fuel	23
3.4 Mount on a truss	26
3.5 Connecting the machine	29
3.6 Setup multiple machines in a sequence with DMX	31
3.7 Let's FLAME!	32
4 Troubleshooting	34
5 Maintenance	34
6 Correct disposal	37
7 EC Declaration of Conformity	39

FOREWORD

Congratulations! You have bought a great new product from MAGIC FX.

This manual contains all information required for the intended use of the equipment. Deviation from the described intended use can result in a hazardous situation and/or property damage.

This manual includes notes and warnings on safe operation of the equipment. These notes and warnings are accompanied by the following icons. Read them attentively!

⚠ DANGER

Indicates a hazardous situation that, if not avoided, will result in death or serious injury. This signal word is to be limited to the most extreme situations.

⚠ WARNING

Indicates a hazardous situation that, if not avoided, could result in death or serious injury.

⚠ CAUTION

Indicates a hazardous situation that, if not avoided, could result in minor or moderate injury.

NOTICE

Indicates information considered important, but not hazard-related (e.g. messages relating to property damage).

LANGUAGE

This document contains the original instructions in English. In case you require other languages please contact MAGIC FX.

REVISION TABLE

Doc nr	Revision	Date	Description	Author	Approved
PART01875	01-00	03-6-2020	Initial release	MB, ES	RD
PART01875	01-01	27-10-2020	Updated graphics	PW	LL

1 MEET THE FLAMEBLAZER®!

The MAGICFX FLAMEBLAZER® is a special effects machine for controlled emission of flame jets into the air in a fixed direction.

The machine uses specific flammable fuels that are projected from a single outlet across spark ignition probes to produce the flame jet. An integrated electric pump draws the fuel from the 5 L can and generates the firing pressure.

There are three nozzles available with the MAGICFX FLAMEBLAZER® which are interchangeable, allowing the user to choose a small, medium or large flame. Based on zero wind the sizes are as follows:

- L nozzle, up to 10 m (included);
- S nozzle, up to 6 m (accessory);
- M nozzle, up to 8 m (accessory).

A specific nozzle exchange tool is available to change between the S, M and L nozzles (SFX 1404)

The FLAMEBLAZER® has a dedicated safety circuit so must be used in conjunction with a MAGICFX® FX-ARM CONTROLLER (MFX 3220).

The MAGICFX FLAMEBLAZER® is fitted for operation:

- With DMX and RDM;
- With an external Low Voltage Pyro input (typical 12-40 Vdc);
- In sequence with multiple machines.

1.1 MAIN PARTS

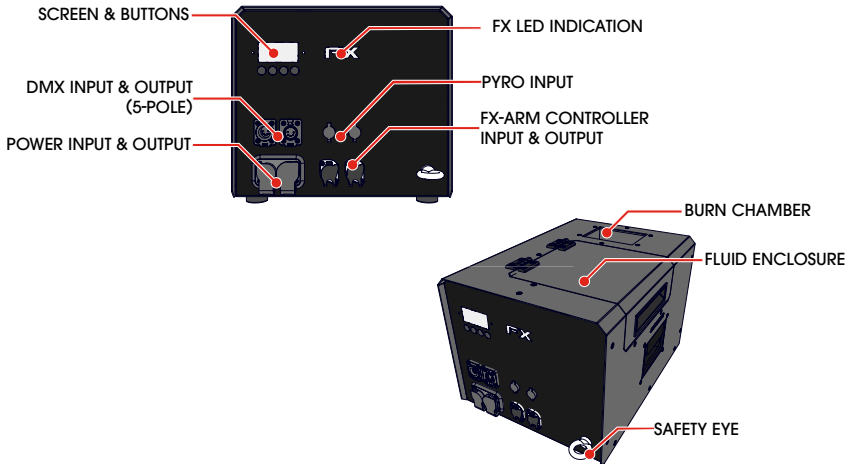

Main parts

1.2 MAGICFX FLAMEBLAZER® FUEL

The MAGICFX FLAMEBLAZER® uses two types of fuel to create the effect. The fuel is loaded into an ADR Can 5 L located in the machine.

NOTICE

Only use these types of fuel: Isopropanol, ISOPAR G, H & L. The use of other fuels or water may degrade the performance of the machine or cause internal damage.

CAUTION

Fuels are highly flammable and must be handled with caution and in accordance with local health and safety regulations. Always follow the safety instructions from the fuel packaging when handling and working with the fuel.

1.3 TECHNICAL DATA

Product	Product Name	MAGICFX FLAMEBLAZER®	
	Product Code	MFX1401	
	Product Type	FLAME FX	
Main Dimensions	Length	410 mm	16.4 in
	Width	300 mm	11.8 in
	Height	281 mm	11 in
Weight	Empty Weight	18.7 kg	41 lbs
Package	Length	540 mm	21.3 in
	Width	400 mm	15.7 in
	Height	420 mm	16.5 in
	Packaged Weight	20.7 kg	45.6 lbs
Environment	Minimum Temperature	-10 °C	14 °F
	Maximum Temperature)	50 °C	122 °F
	Humidity (Relative)	20 % to 90 % (non condensing)	
Electrical	Voltage Input	220-250 Vac	
	Voltage Frequency	50-60 Hz	
	Power Consumption	370 W	
	Power Connector	Neutrik® powerCON TRUE1 (in&out)	
Controlling	Control Options	DMX / Pyro	
	Control Protocols	DMX512-A (ANSI E1.11) RDM (ANSI E1.20) ≈ 9-40 Vdc	
	Control Connectors	Neutrik® 5-pole male/ female XLR 4 mm banana socket	
Arm Controlling	Control Connectors	Neutrik® etherCON / RJ45	
Configuring	Configure Options	On Device & RDM	
Usage	Consumable(s)	Isopropanol, ISOPAR G, H & L	
	Consumable Consumption	S nozzle: ≈ 12 ml/s	
		M nozzle: ≈ 30 ml/s	
		L nozzle: ≈ 50 ml/s	

Technical data

1.4 PRODUCT IDENTIFICATION



Type plate

1.5 ACCESSORIES

Code	Product	Included
SFX1401	MAGICFX FLAMEBLAZER® Nozzle S	
SFX1402	MAGICFX FLAMEBLAZER® Nozzle M	
SFX1403	MAGICFX FLAMEBLAZER® Nozzle L	1x
SFX1404	MAGICFX FLAMEBLAZER® Nozzle exchange tool	
MF0313	Schuko to Neutrik® powerCON TRUE1 cable - 1.5 m	
MF0305	MAGICFX® BASEPLATE II	
MF3106	Doughty Half Coupler (100 kg) M10	
SPR00119	Safety Steel	
SPR01885	Empty ADR Can 5 L (w/out Cap)	1x
SPR90106	MAGICFX FLAMEBLAZER® CUSTOM CAN CAP 5L	1x
MF3220	MAGICFX® FX-ARM CONTROLLER	
MF3080	MAGICFX® Flame Fluid IPA 5L	
MF3086	MAGICFX® Flame Fluid Isopar L 5L	

Accessories

Please contact MAGIC FX for additional possibilities.

1.6 DMX CONTROL

The MAGICFX FLAMEBLAZER® is controlled with 1 enable address and 1 operational address:

DMX address	Address range	Control
Enable address	1 - 512	Device enable/disable
Start address	1 - 512	Effect trigger

DMX addresses

The enable address cannot be the same as the operational address. Operating of these addresses results in the following:

DMX address	DMX Value (decimal)		Result
Enable address	0	99	Device disabled
	100	154	Device enabled
	155	255	Device disabled
Start address (Effect trigger)	0	199	No output
	200	255	Output effect

Operation of the DMX addresses

NOTICE

The maximum continuous duration of the effect is 5 seconds. After this period the effect will stop automatically. To start the effect again you must disable and re-enable the Effect trigger.

NOTICE

Always plug in a DMX Terminator into the DMX output of the final unit in the control sequence. Using a DMX Terminator improves signal reliability.

1.7 DISPLAY PANEL

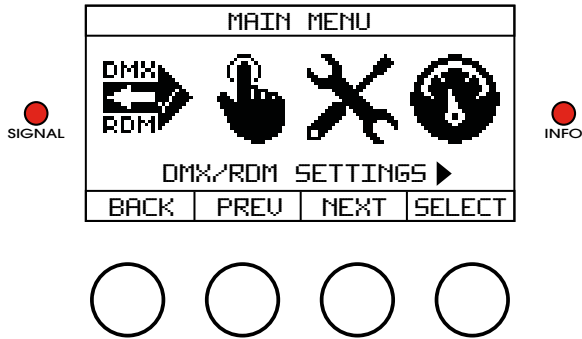

Display panel

The display panel is located on the backside of the MAGICFX FLAMEBLAZER®. Check the following menu structure for all options in the menu. Use the buttons for navigation and selection. The signal LED blinks red when DMX signal is active. The info LED continuously lights red when an error is present.

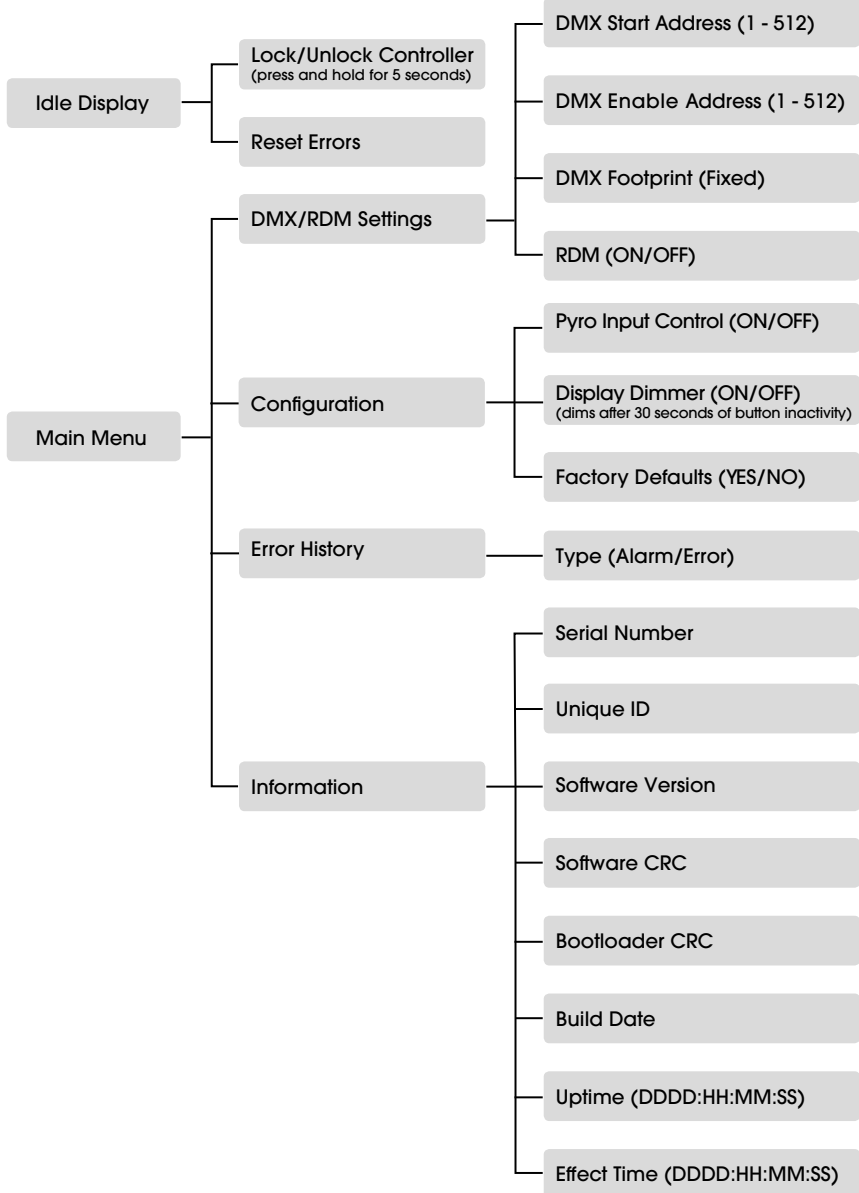

Menu function	Explanation
Lock/Unlock Controller	Holding the Lock button for more than 5 seconds will “lock” the display functions. Meaning buttons will not respond. This to avoid accidental change of parameters via display. To unlock, hold the Unlock button for more than 5 seconds. In case system is armed display is locked.
Reset Errors	In case there is a locking error present, this button will reset the appliance. If the fault does not persist, the locking error will not reappear.
DMX Start Address (1-512)	Setting the DMX start address.
DMX Enable Address (1-512)	Setting the DMX Enable Address.
DMX Footprint	This parameter indicates the DMX footprint, in other words the amount of sequential channels used by the appliance. This does not include the enable channel.
RDM (On/Off)	Use this function to turn on/off the RDM functionality.
Pyro Input Control (On/Off)	Use this function to toggle between the control modes DMX and Pyro
Display Dimmer (On/Off)	Turn display dimmer on or off. If turned on, the display is dimmed automatically 30 seconds after the last button push.
Factory Defaults (Yes/No)	Restores the appliance factory default settings.
Type (Alarm/Error)	Toggle between the occurred locking error (Alarm) list, and blocking error (Error) list. Locking errors need intervention by user, although they are “auto-reset” 3 times before the appliance remains in error until reset by user. Blocking errors clear when the triggering fault disappears. 16 locked, and 16 blocked errors are logged. Top of the list shows the last occurring error.
Serial Number (DDDDD)	Appliance serial number as also printed on the appliance label.
Unique ID (HHHHHHHHHH)	UID number as the appliance appears in the RDM device list after running discovery.
Software Version	Installed software version.
Software CRC	CRC of the functional software.
Bootloader CRC	CRC of the bootloader software.
Build Date	Release date of functional software.
Uptime (DDDD:HH:MMSS)	Time counter which indicates how long the appliance has been powered in total.
Effect Time (DDDD:HH:MMSS)	Time counter which indicates how long the effect has been on in total.

Menu functions

1.8 RDM CAPABILITY

Remote Device Management Protocol (RDM) is an enhancement of the DMX512 communication protocol. RDM can be used for configuration and status monitoring while DMX512 takes care of the default controlling.

For RDM you will need a RDM compatible controller.

The following RDM parameters are supported by the MAGICFX FLAMEBLAZER®.

Parameter ID	Discovery	GET	SET
DISC_UNIQUE_BRANCH	X		
DISC_MUTE	X		
DISC_UN_MUTE	X		
DEVICE_INFO		X	
SUPPORTED_PARAMETERS		X	
SOFTWARE_VERSION_LABEL		X	
DEVICE_MODEL_DESCRIPTION		X	
MANUFACTURER_LABEL		X	
SLOT_DESCRIPTION		X	
DMX_PERSONALITY_DESCRIPTION		X	
SENSOR_DEFINITION		X	
SENSOR_VALUE		X	
DMX_START_ADDRESS		X	X
IDENTIFY_DEVICE		X	X
DEVICE_LABEL		X	X
FACTORY_DEFAULTS		X	X
DMX_PERSONALITY		X	X
RESET_DEVICE			X

RDM parameters

RDM parameters are subject of change due to software updates. Contact MAGIC FX for the latest information and updates.

2 FLAME SAFELY!

The MAGICFX FLAMEBLAZER® has been designed and constructed in such a manner that it can be used safely. This applies to the use, the circumstances and the regulations as described in this documentation. Reading this documentation and following the instructions are therefore necessary for everyone who is authorised to work with the MAGICFX FLAMEBLAZER®.

The MAGICFX FLAMEBLAZER® must be used in surroundings that:

- Have a reasonably stable temperature of between -10 and 50 °C;
- Have a relative humidity degree between 20 % and 90 % (non condensing);
- Are free of dust, corrosive gases and high concentrations of organic vapours.

2.1 GENERAL SAFETY RULES

- Only authorised persons may work with the MAGICFX FLAMEBLAZER®;
- Do not use the MAGICFX FLAMEBLAZER® if there are people or animals in the direct output;
- Make sure that children, unauthorised people and animals do not obtain access to the MAGICFX FLAMEBLAZER®;
- Do not use consumable fuel outside of the design intent as may lead to damage to the hardware, or hazardous situation to property and people;
- Do not use incorrect nozzles as may lead to damage to property or injury to people. (Product supplied with L nozzle);
- Do not connect more units to a single electrical circuit than the installed fuse is able to handle. (Calculate the summed load with the electrical data from Chapter 1);
- Do not remove or bypass any safeguards and safety symbols.
- All required safety devices must be in good condition and function properly;
- Ensure sufficient lighting of the surroundings;
- Keep the workplace clean.





2.2 RIGGING

Please follow the European and national guidelines for safe rigging and trussing.

2.3 NOISE LEVELS

The measured maximum noise levels of the product is 79 dB(A) at 3 m distance away. Please follow the European and national guidelines regarding hearing protection.

2.4 SAFETY SYMBOLS

Symbol	Meaning	Position
	Read the manual carefully before use!	Front of the machine.
	Warning: Hot Surface! Do not touch.	Top of the machine, near the flame outlet.
	Warning: Flammable Fluid. Inside the ADR 5L can, the internal machine pipework and projected from the flame outlet.	Front of the machine.
	Warning: High Pressure. High Pressure liquid inside the internal machine pipework and projected from the flame outlet.	Front of the machine.
	Warning: High Voltage. The ignition probes in the flame outlet chamber during operation.	Top of the machine, near the flame outlet.

Safety symbols

2.5 SAFETY WARNINGS



Eye contact with fuel under pressure and burning fuel from the machine can lead to serious eye injury. Always wear safety goggles when you enter the safety zone.



Fuels are highly flammable and must be handled with caution and in accordance with local health and safety regulations. Always follow the safety instructions from the fuel packaging when handling and working with the fuel.



Make sure there are no objects near the machine and within the output distance that can be damaged or catch fire by the emitted flame and fuel from the MAGICFX FLAMEBLAZER®.

⚠ WARNING

Make sure there are no substances or gasses present that can be ignited by the emitted flame and fuel from the MAGICFX FLAMEBLAZER®.

⚠ WARNING

Using a damaged or an improper installed machine can lead to death, serious injury or property damage. Always inspect the machine thoroughly before operation.

⚠ WARNING

Stop operating the machine immediately if emitted fuel catches fire on the unit or in the burn chamber. Extinguish any burning fuels with Carbon Dioxide, sand or foam. Consult the safety data sheet from the supplier for detailed safety instructions.

⚠ WARNING

Always create a suitable safety zone around the effect of the MAGICFX FLAMEBLAZER®. Furthermore, keep a clearance of an additional 50 % from the maximum height range of the installed e.g. S nozzle has a height range of up to 6 m so needs 9 m clearance above (6 m + 50 %). The advised safety zones depend on the size of the nozzle as each produces a different size flame as follows:

- S nozzle = 2 m;
- M nozzle = 2.5 m;
- L nozzle = 3 m.

Note that the zone direction shifts accordingly when the machine is installed in a tilted position.

Note that the zone shifts and increases with wind. As an approximate guide the distance measurement from the wind speed (in m/s) should be added to the standard safety zone e.g. wind speed of 5 m/s can add 5 m to the typical 3 m resulting in an 8 m safety zone in the direction of wind.



⚠ WARNING

Missing or obscured safety symbols on the machine can lead to death or serious injury. Make sure all safety symbols are correctly in place, see section 2.3.

⚠ CAUTION

The flame output burn chamber and enclosure heats up during operation and can cause burns when touched. Do not touch any metal parts of a (recently) triggered machine.

⚠ CAUTION

Any material that blocks the output nozzle can result in injuries, fire and damage to the machine when the machine is used. Always inspect the nozzle before operating and remove any obstructing material.

⚠ CAUTION

Only open the enclosure access lid when the machine is not powered.

⚠ CAUTION

The MAGICFX FLAMEBLAZER® should not be used in winds exceeding 20 m/h or 32 km/h.

NOTICE

Always keep the machine dry and do not let excessive amounts of liquids such as rain or snow wet the machine.

3 LET'S FLAME!

NOTICE

The MAGICFX FLAMEBLAZER® will also remain functioning correctly when angled at a maximum of 45° or -45°. However the 5 L fuel can will be tipped and may cause a reduction in available fuel to the machine so level installation is preferred.

front view

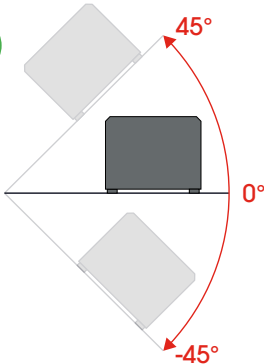

side view

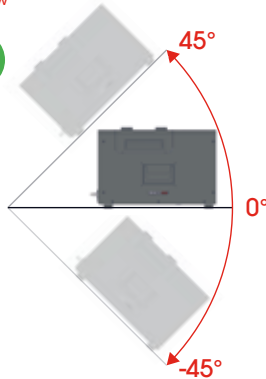

3.1 INSTALL THE MACHINE

- 1 Install the MAGICFX FLAMEBLAZER® on a firm and preferably level surface.
- 2 Inspect the machine and remove any foreign objects and material that will block or obscure the nozzle or ignition probes of the machine during operation.

-
- 3** Take the necessary safety precautions, including:
- a) Creating a safety zone with a distance of 3 m around the effect of the MAGICFX FLAMEBLAZER® and a suitable clearance height depending on nozzle size. This is calculated by taking the maximum height of the installed nozzle and adding 50 % safety factor as follows:
 - S nozzle = 9 m (6 m + 50 %);
 - M nozzle = 12 m (8 m + 50 %);
 - L nozzle = 15 m (10 m + 50 %).
 - b) Making sure that the direct output will be free from persons, animals and property.
 - c) Making sure there are no objects near the machine and within the output distance that can be damaged or catch fire by the emitted heat, flame and fuel from the MAGICFX FLAMEBLAZER®.
-

3.2 CHOOSE THE FLAME HEIGHT

NOTICE

The machine is supplied with an L nozzle installed which produces up to a 10 m flame.

- 1** Choose a flame height that is safe for the environment and rigging position of the MAGICFX FLAMEBLAZER® and select the nozzle that will ensure the flame cannot exceed the physical limitations of this location.
- S nozzle, up to 6 m;
 - M nozzle, up to 8 m;
 - L nozzle, up to 10 m.



⚠ WARNING

Operating the machine with a nozzle that does not have the sufficient safety clearances is dangerous and can cause damage to property and injury to people or animals.

-
- 2 To remove the nozzle from the burn chamber place the MAGICFX FLAMEBLAZER® Nozzle exchange tool over the hex head of the nozzle being careful not to touch or miss-align the ignition probes.

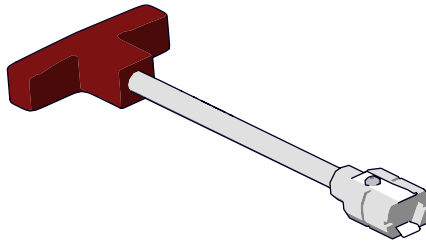

NOTICE

The machine should be on level ground and the burn chamber clean of foreign objects and materials.

- 3 With the MAGICFX FLAMEBLAZER® Nozzle exchange tool held in a vertical position, continuous anti-clockwise rotation will result in the nozzle becoming free from the bulkhead.

This can be lifted out of the burn chamber and the nozzle exchange tool should retain the nozzle with the internal sprung clip.

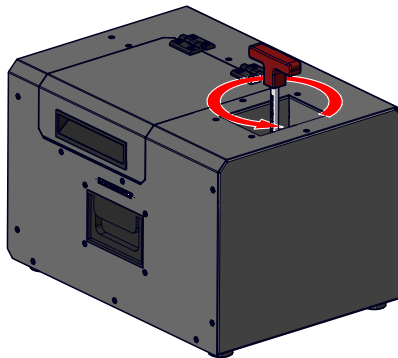

⚠ WARNING

Eye contact with fuel under pressure from the machine can lead to serious eye injury. Always wear eye protection when you change the nozzle.

⚠ CAUTION

Nozzle removal will result in the exposure of residual flammable fuel in the resulting orifice. Caution should be exercised to make sure this cannot be ignited.

NOTICE

Ensure the washer seal remains with the nozzle when it is removed and does not stay in the burn chamber potentially obstructing the new nozzle from sealing properly.

- 4 Replace the nozzle that is not needed for the new nozzle and locate it in the socket of the MAGICFX FLAMEBLAZER® Nozzle exchange tool ready for installation, checking it has a washer seal.

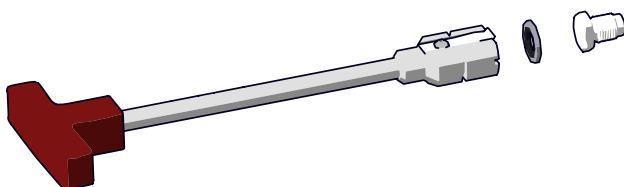

-
- 5 Carefully lower the MAGICFX FLAMEBLAZER® Nozzle exchange tool with nozzle into the burn chamber until the nozzle locates into the bulkhead orifice. Rotate anti-clockwise until a click is heard or felt to check the threads are aligned.

Make sure the tool is held vertical, continuous clockwise rotation will tighten the nozzle into place.

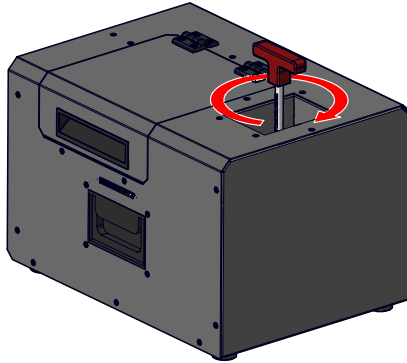

NOTICE

The nozzle quickly goes from loose to tight as the seal meets the bulkhead and does not need to be tightened with excessive force. 12 Nm is sufficient for a good seal.

⚠ CAUTION

Check there is no foreign objects or material in the bulkhead orifice prior to inserting the nozzle as this can lead to blockages or misfires resulting in a dangerous situation.

⚠ CAUTION

Cross-threading the nozzle into the bulkhead, under tightening or not using a ring seal will cause a poor seal resulting in fuel leaks in the burn chamber.

3.3 (RE)FILL THE FUEL

⚠ WARNING

Always make sure that the machine is disarmed and not enabled (FX LED indicator on the machine is dimmed) when you approach a machine.

⚠ WARNING

Eye contact with fuel under pressure and burning fuel from the machine can lead to serious eye injury. Always wear eye protection when you come near a powered machine.

⚠ CAUTION

The flame output burn chamber and enclosure heats up during operation and could cause burns when touched. Do not touch any metal parts of a (recently) triggered machine.

- 1 Disconnect the machine from the power supply.
 - 2 Open the enclosure access lid.
-



⚠ CAUTION

Fuels are highly flammable and must be handled with caution and in accordance with local health and safety regulations. Always follow the safety instructions from the fuel packaging when handling and working with the fuels.

-
- 3** To remove the 5 L can from the housing pull back the sleeve of the quick release coupling to disconnect the fuel hose and remove the can from the enclosure. Once removed unscrew and disconnect the screw cap, hose and quick release coupling from the old can.

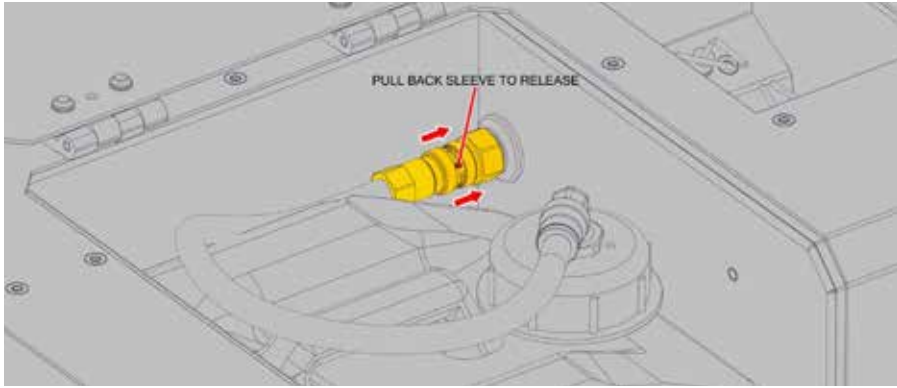

- 4** Insert the dip hose into the new 5 L can so that it touches the bottom and securely fit the screw cap to the can making sure it is tight and will not leak. Place the can into the housing so the cap is furthest away from the control panel.



-
- 5** Push the fuel hose into the quick release coupling on the machine, checking it has engaged properly.

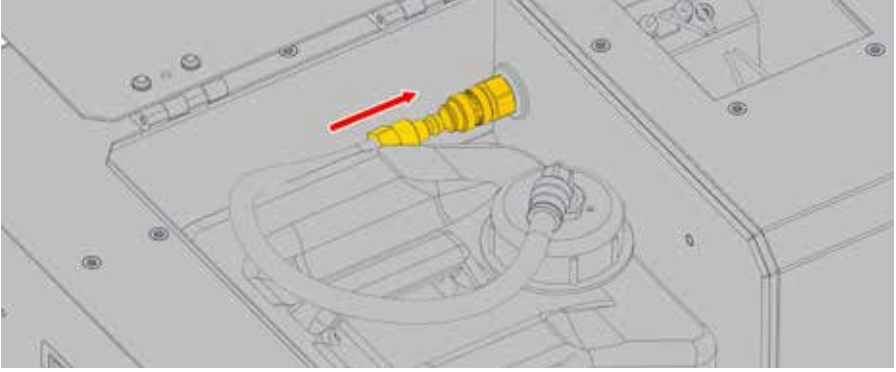

-
- 6** Close the enclosure access lid.

3.4 MOUNT ON A TRUSS

NOTICE

Use a MAGICFX® BASEPLATE II for mounting on top of an upright truss, see the User and Installation manual of the MAGICFX® BASEPLATE II (MFX0305).

- 1 Screw two clamps into threaded holes on the bottom of the machine. Use two Doughty Half Couplers M10 for truss mounting (product code MFX3106) and place the pair in x or in y direction.

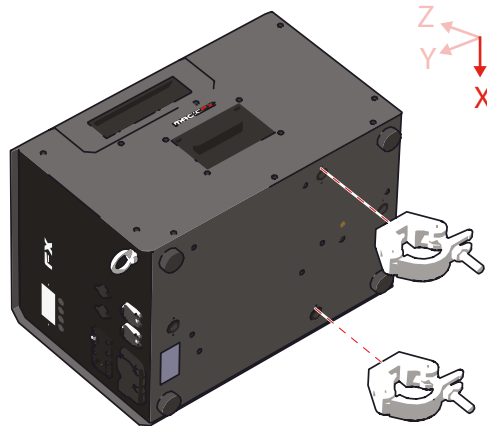
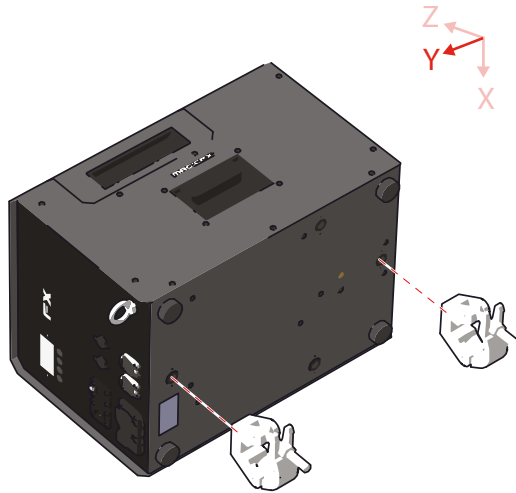

-
- 2** Mount the half coupler on a truss and secure with a certified safety cable. Secure the MAGICFX FLAMEBLAZER® onto the truss.

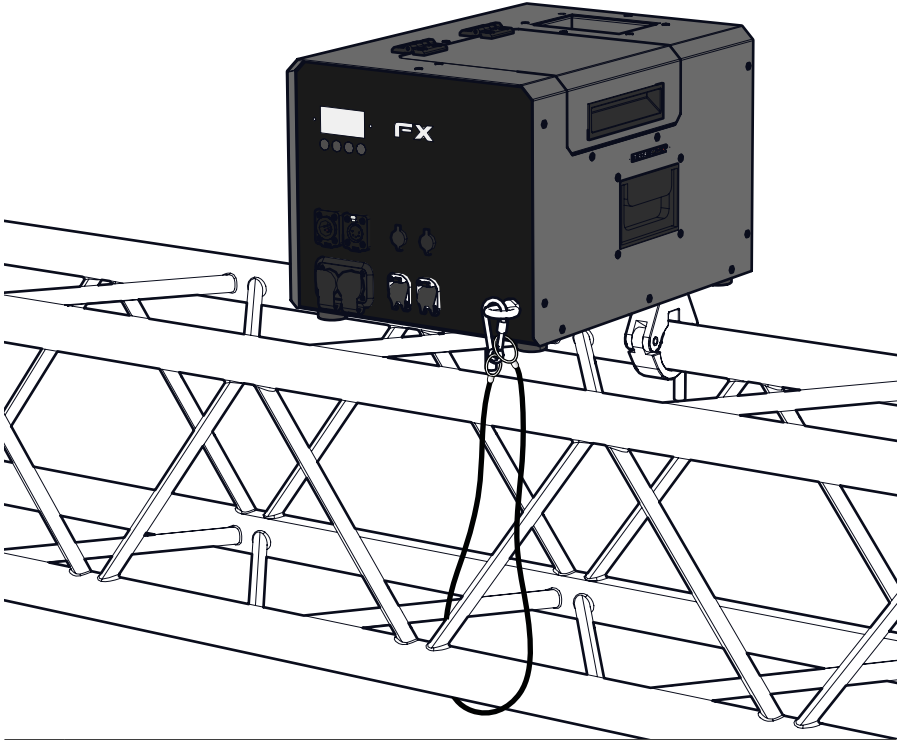

-
- 3** Inspect if the MAGICFX FLAMEBLAZER® is mounted firmly and secured correctly.

-
- 4** Inspect the machine and remove any foreign objects and material that will block or obscure the nozzle or ignition probes of the machine during operation.
-

-
- 5** Take the necessary safety precautions, including:
- a) Creating a safety zone with a distance of 3 m around the effect of the MAGICFX FLAMEBLAZER® and a suitable clearance height depending on nozzle size. This is calculated by taking the maximum height of the installed nozzle and adding 50 % safety factor as follows:
 - S nozzle = 9 m (6 m + 50 %);
 - M nozzle = 12 m (8 m + 50 %);
 - L nozzle = 15 m (10 m + 50 %).
 - b) Making sure that the direct output will be free from persons, animals and property.
 - c) Making sure there are no objects near the machine and within the output distance that can be damaged or catch fire by the emitted heat, flame and fuel from the MAGICFX FLAMEBLAZER®.
-

3.5 CONNECTING THE MACHINE

- 1 Make sure the DMX or Pyro controller is disconnected from power or power switch is disabled.
- 2 If DMX is used, follow the next steps:
 1. Connect an arm cable to the arm in connector on the machine.
 2. Connect the other end of the arm cable to the MAGICFX® FX-ARM CONTROLLER.
 3. Connect the female connector of a 5-pole DMX cable in the DMX input.
 4. Connect the other end of the DMX cable to the DMX controller.
 5. Connect a power cable with a PowerCon TRUE1 female connector to a 220-250 Vac (50-60 Hz) power source.
 6. Connect the other end of the power cable to the power input. The screen will light up.
 7. Use the display and buttons or a RDM controller to assign DMX addresses and check if the signal LED flashes (see Chapter 1). This indicates the DMX signal is applied.

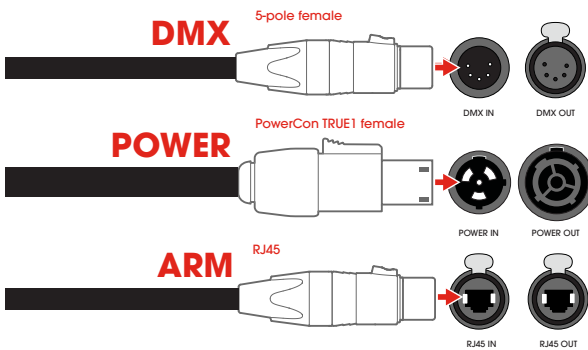

NOTICE

Make sure Pyro Input Control is set to OFF otherwise the DMX signal LED will not flash, even when there is a DMX signal applied.

⚠ WARNING

Only one MAGICFX® FX-ARM CONTROLLER can be used in a single connected system. Connecting more than one controller with RJ45 Arm leads can cause damage to them.

3 If pyro is used, follow the next steps:

1. Connect an arm cable to the arm in connector on the machine.
2. Connect the other end of the arm cable to the MAGICFX® FX-ARM CONTROLLER.
3. Connect the power cables to the 9-40 Vdc in pyro connector.
4. Connect the other end of the power cables to the external low voltage pyro controller (9-40 Vdc).
5. Connect a power cable with a PowerCon TRUE1 female connector to a 220-250 Vac (50-60 Hz) power source.
6. Connect the other end of the power cable to the power input. The screen will light up.
7. Use the display and buttons to set Pyro Input Control to ON.

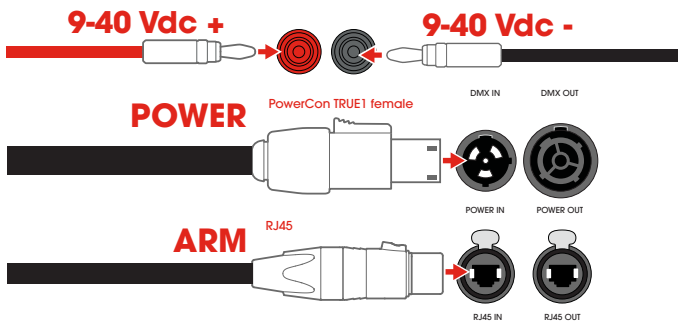
**NOTICE**

When using the pyro Input Control method, make sure Pyro Input Control is set to ON. The DMX signal LED will not light up.

3.6 SETUP MULTIPLE MACHINES IN A SEQUENCE WITH DMX

CAUTION

Do not connect more units to a single electrical circuit than the installed fuse is able to handle. (Calculate the summed load with the electrical data from Chapter 1)

NOTICE

Always plug in a DMX Terminator into the DMX output of the final unit in the control sequence. Using a DMX Terminator improves signal reliability.

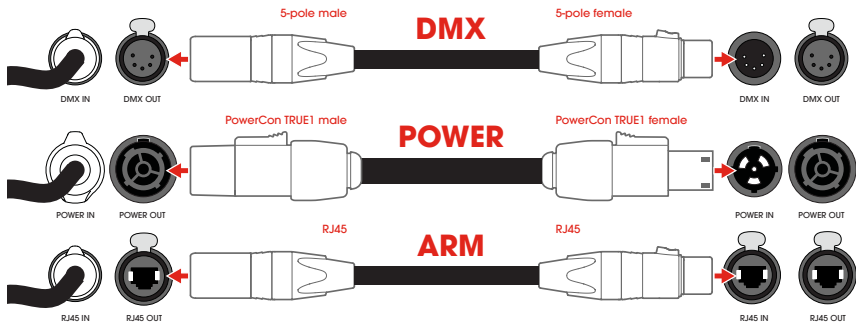
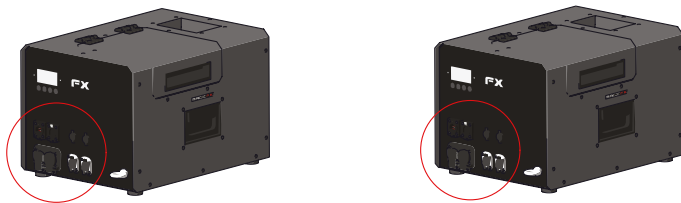

Optionally connect another machine to the power output with a power link cable. If DMX is used, follow the next steps:

1. Connect a power link cable between the power output and the power input of the next machine.
2. Connect an arm cable between the arm out connector and the arm in connector of the next machine.
3. Connect a DMX cable between the DMX output and the DMX input of the next machine.
4. Use the buttons or a RDM controller to assign DMX addresses, see Chapter 1.
5. Repeat step 1 to 4 for each subsequent machine.

3.7 LET'S FLAME!

⚠ CAUTION

Wind can influence the effect and cause flames and fuel to divert off vertical.

- 1 If DMX is used, follow the next steps:
 1. Power the machine.
 2. Make sure that the prescribed safety zone is clear and there is a suitable clearance above the unit for the chosen nozzle.
 3. Ensure the e-stop is released, the reset button is not illuminated and move the MAGICFX® FX-ARM CONTROLLER key into the on position. The FX LED indicator on both the MAGICFX® FX-ARM CONTROLLER and MAGICFX FLAMEBLAZER® lights up continuously. In Pyro Control Mode the FX LED indicator on the machine will flash immediately.
 4. Activate the DMX enable address. The FX LED indicator on the machine will flash.
 5. When it's time to flame, set the DMX value for **Effect trigger** between 200 and 255.
 6. Enjoy the view!
 7. Set the DMX value for **Effect trigger** between 0 and 199 if you want to stop flaming.
 8. Always disarm when done firing. This also includes disabling the DMX enable signal.

NOTICE

The maximum continuous duration of the effect is 5 seconds. After this period the effect will stop automatically. To start the effect again you must disable and re-enable the **Effect trigger**.

NOTICE

Directly after moving the MAGICFX® FX-ARM CONTROLLER key to the ON position the pump will activate.

-
- 2** If pyro is used, follow the next steps:
- 1.** Power the machine.
 - 2.** Make sure that the prescribed safety zone is clear and there is a suitable clearance above the unit for the chosen nozzle.
 - 3.** Ensure the e-stop is released, the reset button is not illuminated and move the MAGICFX® FX-ARM CONTROLLER key into the on position. The FX LED indicator on the MAGICFX® FX-ARM CONTROLLER lights up continuously and the FX LED indicator on the machine flashes immediately.
 - 4.** When it's time to flame, turn on a 9-40 Vdc signal from the pyro controller to the pyro input.
 - 5.** Enjoy the view!
 - 6.** Turn off the 9-40 Vdc signal from the pyro controller if you want to stop flaming.
 - 7.** Always disarm when done firing.

NOTICE

The maximum continuous duration of the effect is 5 seconds. After this period the effect will stop automatically. To start the effect again you must disable and re-enable the 9-40 Vdc.

NOTICE

Directly after moving the MAGICFX® FX-ARM CONTROLLER key to the ON position the pump will activate.

4 TROUBLESHOOTING

Code	Meaning	Solution
018	Pressure keeps dropping.	<ul style="list-style-type: none">• Make sure the fuel can is not empty.• If the problem is not solved contact MAGIC FX.
020	Pressure Sensor Failure.	<ul style="list-style-type: none">• Contact MAGIC FX.
121	Orientation of device out of safe bounds.	<ul style="list-style-type: none">• Keep the device within previously described safe bounds.

Always contact MAGIC FX if any malfunctions or errors occur that cannot be solved with the instructions as described in this manual.

5 MAINTENANCE

To achieve the maximum service life of the MAGICFX FLAMEBLAZER® you must regularly clean the MAGICFX FLAMEBLAZER® and test if it is functioning correctly.

Before conducting any maintenance ensure the machine is switched off and disconnected from a power source and the machine is not hot from recently being used. Always use personal protective equipment such as safety glasses and gloves when handling fuels.

Maintenance task	Activity
General clean.	Remove any foreign objects from burn chamber before every use being careful not to move or damage the spark ignition probes. Remove any dust or dirt from hose connections with a non-abrasive damp cloth.
Inspect and clean nozzles.	Remove nozzle with MAGICFX FLAMEBLAZER® Nozzle exchange tool. Submerge nozzle in Isopropanol for minimum of 1 minute. Remove from solution and when dry use compressed air to blow through the nozzle in opposite direction of fuel. Before inserting nozzle back into machine conduct a visual check of the washer seal to make sure no damage to the soft material and replace the washer seal if damaged.

Inspect and clean spark ignition probes.

Any foreign particles should be removed from the probes, which can be cleaned with Isopropanol and a light abrasive cloth. Ignition probes should not be adjusted from the factory setting as this is critical to safe and reliable ignition. To check they are in the correct position each pair of probes must have a gap from tip to tip of 4 mm (+/-2 mm) and opposite probes must have a gap from tip to tip of 16 mm (+2 mm). If they do not have these gaps or are miss-aligned in anyway contact MAGIC FX.

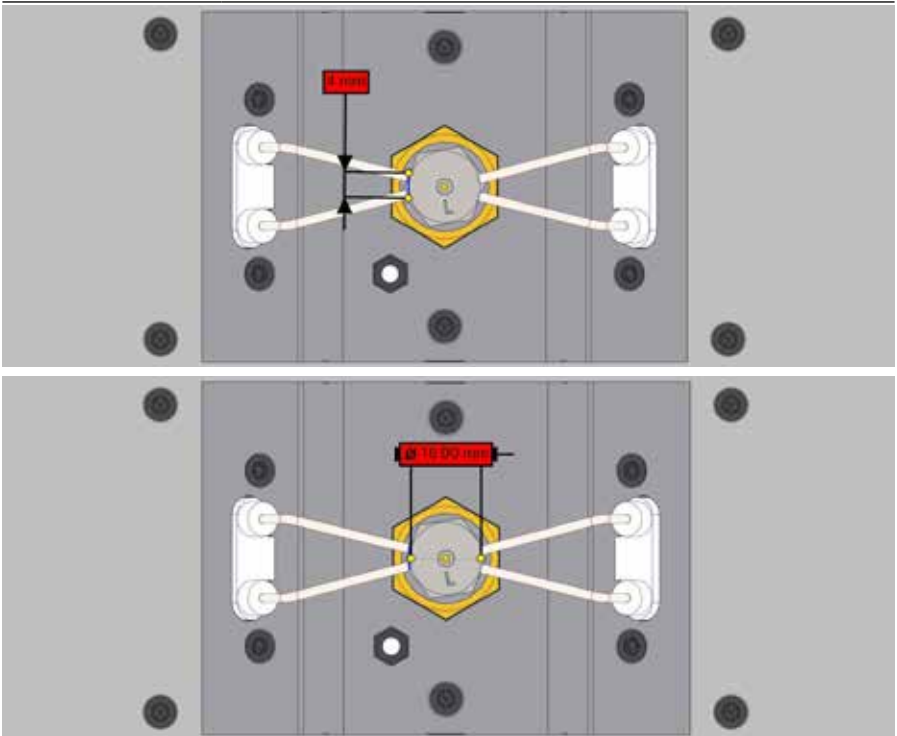

Contact MAGIC FX if the MAGICFX FLAMEBLAZER® is not functioning correctly.

Firmware updates can add additional features and fix bugs so regularly check on the website or with your MAGIC FX account manager to ensure you have the latest version.

⚠ DANGER

Do not replace parts yourself; always consult MAGIC FX if necessary.

6 CORRECT DISPOSAL



This symbol on the product and / or accompanying documents means that used electrical and electronic products should not be mixed with general household waste. For proper treatment, recovery and recycling, please take this product to designated collection points where it will be accepted free of charge.

Alternatively, in some countries you may be able to return your products to your local retailer upon purchase of an equivalent new product.

Disposing of this product correctly will help save valuable resources and prevent any potential negative effects on human health and the environment, which could otherwise arise from inappropriate waste handling.

Please contact your local authority for further details of your nearest designated collection point.

Penalties may be applicable for incorrect disposal of this waste, in accordance with your national legislation.

7 EC DECLARATION OF CONFORMITY

According to Annex III A Machinery Directive 2006/42/EC

MAGIC FX B.V. declares as manufacturer and composer of the technical construction file that the product with the following specifications:

Name machine : FLAMEBLAZER® STANDALONE
Type : MFX1401
Voltage : 220-250Vac 50/60Hz
Serial number : on product
Year of construction : on product

Is in conformity with the minimal safety regulations as stated in the following directive(s):

- LVD (2014/35/EU) Low Voltage Directive
- EMC (2014/30/EC) ElectroMagnetic Compatibility
- RoHS (2011/65/EU) Restriction of the use of certain Hazardous Substances
- WEEE (2012/19/EU) Waste Electrical & Electronic Equipment

The following harmonized standards were applied:

- NEN-EN-ISO 12100:2010 Safety of machinery - General principles for design - Risk assessment and risk reduction.
- NEN-EN-IEC 60204-1:2006, Safety of machinery - Electrical equipment of machines - Part 1 General requirements.
- NEN-EN-IEC 61000-6-3:2007/A1:2011, Electromagnetic compatibility (EMC) - Part 6-3: Generic standards - Emission standard for residential, commercial and light-industrial environments.

- Original declaration of conformity
 Translation of the original declaration of conformity

Name manufacturer : MAGIC FX B.V.
Address : Schouwrooij 27, 5281 RE BOXTEL
Country : The Netherlands

CEO : B. Veroude
Date : 6-2-2020

Signature :



MAG:CFX[®]

WWW.MAGICFX.EU

